



CARIBBEAN EXAMINATIONS COUNCIL

**Caribbean Advanced Proficiency Examination
CAPE®**

**BUILDING AND MECHANICAL
ENGINEERING DRAWING
SYLLABUS**

Effective for examinations from May–June 2016

Published in Jamaica by the Caribbean Examinations Council

All rights reserved. No part of this publication may be reproduced, stored in a retrieval system, or transmitted in any form, or by any means electronic, photocopying, recording or otherwise without prior permission of the author or publisher.

Correspondence related to the syllabus should be addressed to:

The Pro-Registrar
Caribbean Examinations Council
Caenwood Centre
37 Arnold Road, Kingston 5, Jamaica

Telephone Number: +1 (876) 630-5200
Facsimile Number: +1 (876) 967-4972
E-mail Address: cxcwzo@cx.org
Website: www.cxc.org

Copyright © 2015 by Caribbean Examinations Council
Prince Road, Pine Plantation Road, St Michael BB11091



Contents

INTRODUCTION.....	i
RATIONALE.....	2
AIMS.....	3
SKILLS AND ABILITIES TO BE ASSESSED	3
PREREQUISITES OF THE SYLLABUS.....	4
STRUCTURE OF THE SYLLABUS.....	4
RECOMMENDED TEACHING APPROACH.....	5
UNIT 1: BUILDING AND MECHANICAL ENGINEERING DRAWING	
MODULE 1: GEOMETRY 1.....	6
MODULE 2: GEOMETRY 2.....	11
MODULE 3A: ENGINEERING DRAWING.....	14
MODULE 3B: BUILDING DRAWING	19
UNIT 2: BUILDING AND ENGINEERING DESIGN	
OPTION A: MECHANICAL ENGINEERING DRAWING AND DESIGN	
MODULE 1: MECHANICS OF MACHINES.....	37
MODULE 2: ENGINEERING MATERIALS AND PROCESSES.....	41
MODULE 3: ENGINEERING DESIGN ELEMENTS.....	45
OPTION B: BUILDING DRAWING AND DESIGN	
MODULE 1: STRUCTURAL DRAWINGS.....	24
MODULE 2: BUILDING MATERIALS AND PROCESSES.....	27
MODULE 3: MANAGEMENT AND DESIGN.....	33

OUTLINE OF ASSESSMENT.....	50
REGULATIONS FOR PRIVATE CANDIDATES.....	65
REGULATIONS FOR RESIT CANDIDATES.....	65
ASSESSMENT GRID.....	66
REFERENCE MATERIAL.....	67
MINIMUM EQUIPMENT LIST.....	67

This document CXCA12/U2/12 replaces CXCA12/U/05 issued in 2005.

Please note that the syllabus has been and amendments are indicated by italics.

First published in 1999

Revised in 2005, 2015

Please check the website www.cxc.org for updates on CXC's syllabuses.



Introduction

The Caribbean Advanced Proficiency Examination (CAPE) is designed to provide certification of the academic, vocational and technical achievement of students in the Caribbean who, having completed a minimum of five years of secondary education, wish to further their studies. The examinations address the skills and knowledge acquired by students under a flexible and articulated system where subjects are organised in 1-Unit or 2-Unit courses with each Unit containing three Modules. Subjects examined under CAPE may be studied concurrently or singly.

The Caribbean Examinations Council offers three types of certification. The first is the award of a certificate showing each CAPE Unit completed. The second is the CAPE Diploma, awarded to candidates who have satisfactorily completed at least six Units, including Caribbean Studies. The third is the CXC Associate Degree, awarded for the satisfactory completion of a prescribed cluster of seven CAPE Units including Caribbean Studies and Communication Studies. For the CAPE diploma and the CXC Associate Degree, candidates must complete the cluster of required Units within a maximum period of five years.

Recognised educational institutions presenting candidates for the CXC Associate Degree in one of the nine categories must, on registering these candidates at the start of the qualifying year, have them confirm, in the required form, the Associate Degree they wish to be awarded. Candidates will not be awarded any possible alternatives for which they did not apply.

Building and Mechanical Engineering Drawing Syllabus

◆ RATIONALE

Building and Mechanical Engineering Drawing (BMED) is the universal *graphic language of communication for individuals in the field of engineering and architecture as well as for technicians and craftsmen*. This type of universal communication is facilitated by the use of standards published by the International Organization for Standardization (ISO) for Engineering Drawing. *Building and Mechanical Engineering Drawing provides a significant contribution to the development of the human resources required for the creation of advanced designing and creative solutions to the twenty-first century demands of industrial production and manufacturing in the Caribbean.*

The course of study for BMED incorporates aspects of architectural drawings of buildings as well as mechanical drawings for the development and communication of design ideas and concepts. As a form of graphical communication, the course provides the student with the opportunity of visualising and comprehending information presented verbally, graphically and mathematically.

A student who completes this syllabus would be experienced in the use of the latest developments of Computer Aided Drawing (CAD). In addition, the student would become dexterous in the application of the British Standard (BS8888), ISO Standards, Caribbean Uniform Building Codes (CUBiC) and other local codes to building and engineering drawings. By pursuing this course, students will develop twenty-first century skills such as creativity, decision-making, problem-solving, critical thinking and collaboration. This syllabus is designed to provide in depth knowledge, skills and competencies that are required for further studies and for the world of work.

This syllabus will contribute to the development of the Ideal Caribbean Person, as articulated by the CARICOM Heads of Government, who: *is emotionally secure with a high level of self-confidence and self-esteem; sees ethnic, religious and other diversity as a source of potential strength and richness; is aware of the importance of living in harmony with the environment; values and displays the creative imagination in its various manifestations and nurtures its development in the economic and entrepreneurial spheres in all other areas of life (Caribbean Education Strategy, 2000).* Based on the UNESCO Pillars of Learning, this course of study will also contribute to a person who will learn how to do, learn to be and learn to transform themselves and society.

The Units, in the syllabus, integrate the Principles of Competency Based Education, Training and Assessment (CBETA) in the School-Based Assessment component. These principles are embedded in the achievement of performance standards based on verifiable evidences. In this new approach, one section of the School-Based Assessment component of the Building and Mechanical Engineering Drawing Syllabus will comprise a relevant level 2 Caribbean Vocational Qualification (CVQ) Unit certification and a School-Based Assessment portfolio. This initiative makes it possible for every student sitting the examinations to exit with dual certification; CAPE certificate and CVQ Unit Certification.

◆ AIMS

The syllabus aims to:

1. develop proficiency in *technical communication* and production of building and mechanical engineering drawings which conform to BS and ISO Standards, CUBiC and local codes;
2. develop skills in the preparation of working and assembly drawings conforming to BS and ISO Standards, CUBiC and local codes;
3. *develop an understanding of the properties, uses and production of materials used in the manufacture of building and engineering components;*
4. provide knowledge of the different methods of production of building and engineering components;
5. *develop skills in communicating technical information using illustrations, scaled models and working drawings to solve engineering design problems;*
6. develop skills in applying and drawing principles to facilitate product development and manufacture;
7. develop *proficiency* in the use of Computer-Aided Drafting (CAD) software, *instruments, media and reference materials* to produce engineering drawings;
8. develop an interest in *architectural or mechanical engineering* as a career and intellectual disciplines;
9. *develop the capacity for critical and creative thinking, problem-solving, leadership and cooperative behaviours through authentic learning experiences.*

◆ SKILLS AND ABILITIES TO BE ASSESSED

The skills and abilities which students are expected to develop on completion of the syllabus have been grouped under three headings:

- (a) Knowledge;
- (b) Application;
- (c) Drawing Skills.

Knowledge: The ability to identify, recall and grasp the meaning of fundamental facts, concepts and principles.

Application: The ability to use facts, concepts, principles and procedures in unfamiliar situations; transform data accurately and appropriately; use common characteristics as a basis for classification; use formulae accurately for computations.

Drawing Skills: The ability to produce neatly organised, clean and accurate drawings according to specification.

◆ PREREQUISITES OF THE SYLLABUS

It is expected that persons with a good grasp of the Building or Mechanical Engineering Drawing Option of the CSEC Technical Drawing or Industrial Technology syllabuses or the equivalent should be able to successfully pursue this course.

◆ STRUCTURE OF THE SYLLABUS

The syllabus is divided into two Units. Each Unit consists of three Modules. The Units are independent of each other. *The syllabus consists of two Units of 150 hours each. Each Unit consists of three Modules of 50 hours each. Each Module is compulsory.* Together they provide a comprehensive post-secondary course in the field of Building and Mechanical Engineering Drawing.

Unit 1: Building and Mechanical Engineering Drawing contains three Modules of approximately 50 hours each. *Unit 1 is designed to provide the students with an all-rounded development experience in building and engineering drawing. Candidates are required to complete Modules 1 and 2 which are compulsory and either Module 3A or Module 3B. The total time for the syllabus is approximately 150 hours.*

Module 1 - Geometry 1
Module 2 - Geometry 2

Options

Module 3A - Engineering Drawing
OR
Module 3B - Building Drawing

Unit 2: Building and Engineering Design contains three Modules of approximately 50 hours each. The total time for the syllabus is approximately 150 hours. Unit 2 offers two options: Option A, Building Drawing and Design, and Option B, Engineering Drawing and Design. Candidates are required to select **either** Option A **or** Option B. The total time for the syllabus is approximately 150 hours.

Option A: Mechanical Engineering Drawing and Design

Module 1	-	Mechanics of Machines
Module 2	-	Engineering Materials and Processes
Module 3	-	Management and Design

Option B: Building Drawing and Design

Module 1	-	Structural Drawings
Module 2	-	Building Materials and Processes
Module 3	-	Building Design Elements

◆ **RECOMMENDED TEACHING APPROACH**

An interdisciplinary approach, catering to different learning styles, is recommended for the effectiveness of the delivery and assessment of the syllabus. This approach promotes the use of problem-based learning and the concepts and principles of constructivism and multiple intelligences thus ensuring that learners are holistically engaged. A hands-on approach is also advocated to allow the students to relate and apply the knowledge gained in real life and authentic situations.

◆ UNIT 1: BUILDING AND MECHANICAL ENGINEERING DRAWING

MODULE 1: GEOMETRY 1

GENERAL OBJECTIVES

On completion of this Module, students should *develop*:

1. the ability to produce two-dimensional drawings;
2. basic Computer-Aided Drafting (CAD) skills.

SPECIFIC OBJECTIVES

Students should be able to:

1. construct standard engineering curves;
2. determine centroids of plane figures by simple calculations and graphical methods;
3. *project solids in orthographic projection*;
4. use Computer-Aided Drafting software to produce drawings.

CONTENT

1. Standard engineering curves

(a) *Definition of engineering curves.*

(b) *Types of engineering curves to include:*

(i) *ellipse;*

(ii) *parabola;*

(iii) *hyperbola;*

(iv) *cycloids;*

(v) *trochoids (inferior and superior);*

(vi) *involutes;*

(vii) *Archimedian spirals.*

UNIT 1

MODULE 1: *GEOMETRY 1* (cont'd)

(c) *Methods of construction of these curves to include true methods.*

(d) *Constructing tangents to these curves.*

2. Centroids

(a) *lines of symmetry.*

(a) *Integration of area.*

(b) First and second moments.

3. Orthographic Projection

(a) *First angle projection.*

(b) *Third angle projection.*

4. Computer-Aided Drafting (CAD)

(a) Polar and *Direct* co-ordinates.

(b) CAD features:

(i) menus;

(ii) *drawing*;

(iii) *toolbars (draw, modify, dimension)*;

(c) *Draw Toolbar*:

(i) draw – line;

(ii) construction line;

(iii) polygon;

(iv) rectangle;

(v) arc;

(vi) circle;

UNIT 1

MODULE 1: *GEOMETRY 1* (cont'd)

- (vii) donut;
 - (viii) spline;
 - (ix) ellipse;
 - (x) block;
 - (xi) hatch;
 - (xii) boundary.
- (d) Modify Toolbar:
- (i) mirror;
 - (ii) array (rectangle, polar);
 - (iii) copy;
 - (iv) rotate;
 - (v) scale;
 - (vi) stretch.
- (e) Dimension Toolbar:
- (i) linear;
 - (ii) aligned;
 - (iii) co-ordinate;
 - (iv) radius;
 - (v) diameter;
 - (vi) angular;
 - (vii) baseline;
 - (viii) continue;

UNIT 1

MODULE 1: *GEOMETRY 1 (cont'd)*

- (ix) leader;
 - (x) tolerance;
 - (xi) centremark;
 - (xii) dimension text edit;
 - (xiii) dimension style.
- (f) CAD software to produce plane geometry drawings.

Suggested Teaching and Learning Activities

To facilitate students' attainment of the objectives in this Module, teachers are advised to engage students in the following teaching and learning activities.

1. Have students solve problems pertaining to the content on Plane Geometry in the recommended texts.
2. Use real life examples to promote class discussion and illustrate the use and purpose of Plane Geometry in Mechanical Engineering.
3. *Sensitise students to* the fundamentals of Mechanical Engineering science with emphasis on definitions and the graphical approach.
4. Emphasise on freehand sketching and different drawing methods.
5. Have students perform relevant calculations where required.
6. Have students use CAD software to produce Plane Geometry drawings.

RESOURCE

Jensen C. Helsel, J., Short D.

Engineering Drawing and Design: Madsen and Madsen, ISBN-13; 978-1-111-30966-4, ISBN-10; 1-111-30966-3, Delmar, Cengage Learning.

UNIT 1

MODULE 2: *GEOMETRY 2*

GENERAL OBJECTIVES

On completion of this Module, students should *develop*:

1. the ability to produce three dimensional drawings;
2. Computer-Aided Drafting (CAD) skills.

SPECIFIC OBJECTIVES

Students should be able to:

1. represent solids in pictorial projections;
2. project auxiliary views;
3. draw lines of intersection between solids;
4. *produce* surface developments;
5. *construct helices*;
6. *use CAD software to produce drawings*.

CONTENT

1. Pictorial projections

(a) Projection:

(i) oblique;

(ii) planometric;

(iii) isometric:

- application of the isometric scale.

(iv) *perspective*:

- *one-point angular*;
- *two-point angular*.

UNIT 1

MODULE 2: *GEOMETRY 2* (cont'd)

- (b) *Constructing* circles and curves in pictorial drawings.

2. **Auxiliary Views**

- (a) The projection of sections of solids cut by inclined planes.
- (b) True shapes of sections.
- (c) First and second auxiliary views.

3. **Intersection of solids**

Intersection and interpenetration of solids.

4. **Surface development**

- (a) Surfaces of right or skewed three-dimensional objects.
- (b) Surfaces composed of multiple geometric shapes.
- (c) Transition pieces (square-to-round, round-to-round).
- (d) Economical use of materials (seam line location).

5. **Helix**

- (a) *Helices on cylindrical forms (screw threads and springs).*
- (b) *Helices on conical forms.*

6. **Use of CAD to produce drawings**

UNIT 1

MODULE 2: *GEOMETRY 2* (cont'd)

Suggested Teaching and Learning Activities

To facilitate students' attainment of the objectives in this Module, teachers are advised to engage students in the following teaching and learning activities.

1. *Have students solve problems pertaining to the content on Solid Geometry in the recommended texts.*
2. *Use real life examples to promote class discussions and illustrate the use and purpose of Solid Geometry in Mechanical Engineering.*
3. *Place emphasis on definitions, freehand sketching and different drawing methods.*
4. *Have students perform relevant calculations where required.*
5. *Have students use CAD software to produce Solid Geometry drawings.*

RESOURCES

- Jackson, E. *Advanced Level Technical Drawing, London: Metric Edition, Longman Group Limited, 1975.*
- Jensen C. Helsel, J., Short D. *Engineering Drawing and Design: Madsen and Madsen, ISBN-13; 978-1-111-30966-4, ISBN-10; 1-111-30966-3, Delmar, Cengage Learning.*

UNIT 1

MODULE 3A: ENGINEERING DRAWING

GENERAL OBJECTIVES

On completion of this Module, students should:

1. *demonstrate the ability to use traditional methods and CAD software to produce engineering drawings;*
2. *develop the ability to draw, sketch freehand and design machine components to specifications and engineering standards.*

SPECIFIC OBJECTIVES

Students should be able to:

1. *prepare detailed freehand sketches of machine parts and components;*
2. *produce working and assembly drawings;*
3. *prepare drawings with sectional views;*
4. *prepare detailed drawings;*
5. *produce dimensional drawings of machine components for manufacturing purposes;*
6. *synthesise solutions to engineering problems;*
7. *construct displacement diagrams for edge, face and cylindrical Cams.*

CONTENTS

1. Freehand Sketching

- (a) Orthographic views of machine parts and components.
- (b) Pictorial views of machine parts and *components*.

2. Working and assembly drawings

- (a) Working drawings:
 - (i) machine parts and components;

UNIT 1

MODULE 3A: ENGINEERING DRAWING (cont'd)

(ii) *using welding and machining symbols;*

(iii) *drawing notations.*

(b) Assembly drawings:

- machine parts and components.

3. ***Drawings with sectional views***

(a) *Machine components.*

(b) *Fasteners including nuts, bolts, pins, washers.*

4. ***Detailed drawings***

(a) *Machine parts.*

(b) *Assembly drawings.*

(c) *Working drawings.*

5. ***Dimensioned drawings***

(a) *General.*

(b) *Manufacturing.*

(c) *Geometric and positional tolerances: finishes, limits and fits (BS 4500).*

(d) *Balloon referencing and part listings:*

(i) *cross-reference;*

(ii) *item list and materials specification.*

6. **Synthesising designs using components selected from the suggested list below.**

(a) Accessories:

(i) gauges;

(ii) small tools;

UNIT 1

MODULE 3A: ENGINEERING DRAWING (cont'd)

- (iii) clamping devices.

- (b) Mechanisms:
 - (i) slide crank and pin;
 - (ii) rack and pinion;
 - (iii) ratchet.

- (c) Fasteners:
 - (i) bolts and nuts;
 - (ii) screws;
 - (iii) studs;
 - (iv) keys, pins, rivets and locking devices.

- (d) Hydraulic Systems

- (e) Pumps:
 - (i) centrifugal;
 - (ii) reciprocating.

- (f) Valves:
 - (i) non-return;
 - (ii) isolating;
 - (iii) expansion;
 - (iv) safety;
 - (v) gate;
 - (vi) globe.

UNIT 1

MODULE 3A: ENGINEERING DRAWING (cont'd)

- (g) Piping and joints:
 - (i) flanged;
 - (ii) hydraulic.
- (h) Seals:
 - (i) dynamic;
 - (ii) static.
- (i) Machines:
Parts of the following machines
 - (i) drilling;
 - (ii) grinding;
 - (iii) lathe;
 - (iv) milling;
 - (v) shaping.

7. *Displacement diagrams for cams*

- (a) *Cam profiles and displacement diagrams to produce:*
 - (i) *dwelling;*
 - (ii) *uniform velocity;*
 - (iii) *uniform acceleration or retardation;*
 - (iv) *simple harmonic motion.*
- (b) *Cam profiles and displacement diagrams with various types of followers, namely:*
 - (i) *knife-edge;*
 - (ii) *roller;*
 - (iii) *flat;*
 - (iv) *spherical.*

UNIT 1

MODULE 3A: ENGINEERING DRAWING (cont'd)

(c) *Cam profiles and displacement diagrams with different follower paths:*

(v) *straight line;*

(vi) *circular arc;*

(vii) *on-centre;*

(viii) *off-centre.*

Suggested Teaching and Learning Activities

To facilitate students' attainment of the objectives in this Module, teachers are advised to engage students in the following teaching and learning activities.

1. Use articles from current periodicals on relevant Mechanical Engineering topics to assist students in adequately covering the design sections of the Module.
2. Have students complete several working and assembly drawings of machine parts and components.
3. Place emphasis on the importance of freehand sketching in enabling students to become familiar with the complexity in the theory and construction of various machine parts and components.
4. Visit mechanical engineering drawing offices to familiarise students with the different conventional representation on drawings and the use and importance of drawing standards.
5. Visit machine and mechanical engineering workshops to familiarise students with the operations.
6. *Arrange guest lectures.*

RESOURCES

- Jackson, E. *Advanced Level Technical Drawing, London: Metric Edition, Longman Group Limited, 1975.*
- Jensen C. Helsel, J., Short D. *Engineering Drawing and Design: Madsen and Madsen, ISBN-13; 978-1-111-30966-4, ISBN-10; 1-111-30966-3, Delmar, Cengage Learning.*

UNIT 1

MODULE 3B: BUILDING DRAWING

GENERAL OBJECTIVES

On completion of this Module, students should develop:

- 1. proficiency in the use of conventional and CAD methods to produce drawings with construction details to building standards;*
- 2. an awareness of the creative and innovative graphic and visualisation skills used for communication in the construction industry.*

SPECIFIC OBJECTIVES

Students should be able to:

- 1. prepare orthographic and pictorial sketches;*
- 2. prepare drawings with sectional views;*
- 3. produce a complete set of drawings using suitable scales;*
- 4. prepare utility drawings.*

CONTENT

1. Sketches or drawings

- (a) Perspective.*
- (b) Exploded isometric.*
- (c) Orthographic.*

2. Drawings with sectional views

Sectional views of:

- (a) a flat roof (concrete and timbers);*
- (b) joint details in windows and doors.*

UNIT 1

MODULE 3B: BUILDING DRAWING (cont'd)

3. Producing and modifying a complete set of building drawings.

(a) Floor Plans:

(i) two storey buildings using appropriate scales:

- *commercial building;*
- *residential (single dwelling);*
- *townhouse/apartment;*
- *split-level structure.*

(ii) buildings outfitted with access for the physically challenged;

(iii) window and door schedules.

(b) Roof plans:

(i) gable or v-shaped roof;

(ii) hip roof;

(iii) bow string or dome roof;

(iv) reinforced concrete roof.

(c) Elevations for two-storey building:

(i) east elevation;

(ii) west elevation;

(iii) south elevation;

(iv) north elevation.

(d) Sectional elevations:

(i) latitude;

(ii) longitude;

(iii) offset.

UNIT 1

MODULE 3B: BUILDING DRAWING (cont'd)

- (e) *Site plans:*
- (i) *position of building on site;*
 - (ii) *setback dimension from building to boundaries;*
 - (iii) *septic tank and soak away pit/ sewer system waste line;*
 - (iv) *drainage (surface and main drain);*
 - (v) *north position;*
 - (vi) *driveway, lawn and vegetation;*
 - (vii) *commercial parking;*
 - (viii) *loading and off-loading bay;*
 - (ix) *handrail from car park to building;*
 - (x) *walkway from car park to building.*
- (f) *Location plans:*
- (i) *street names;*
 - (ii) *business places;*
 - (iii) *electricity poles;*
 - (iv) *landmarks.*
- (g) *Staircase (timber)*
- Types:*
- (i) *Straight flight:*
 - *with landing;*
 - (ii) *'U' Shape;*
 - (iii) *L- flight;*
 - (iv) *Spiral.*

UNIT 1

MODULE 3B: BUILDING DRAWING (cont'd)

- (h) *Foundation Plans:*
 - (i) *footing details;*
 - (ii) *strip footing;*
 - (iii) *pad footing.*
- (i) *Ground Beam Details.*
- (j) *Ground floor slab plan and details.*

4. Utility drawings

- (a) *Electrical:*
 - (i) *symbols and components;*
 - (ii) *layouts.*
- (b) *Plumbing:*
 - (i) *fixtures and fittings;*
 - (ii) *flow diagrams and symbols;*
 - (iii) *pipe drawing layouts;*
 - (iv) *sewer line diagram.*

Suggested Teaching and Learning Activities

Teachers are encouraged to engage students in activities such as those listed below as they seek to achieve the objectives of this Module.

1. *Have students visit the Town and Country Planning office for policies and regulations on Building Codes of Two Storey Building.*
2. *Have students research and deliver presentations on topics contained in the Module.*
3. *Have students visit construction sites (residential and commercial) to observe the use and application of construction materials.*

UNIT 1

MODULE 3B: BUILDING DRAWING (cont'd)

4. *Have students visit drawing offices and architectural firms to observe the process in which drawings are produced.*

RESOURCES

- Chudley, R. and Green, R. Construction Technology, 4th edition , Essex: Pearson Prentice Hall, 2005*
- Krishna N. Structural Design and Drawing: Reinforced Concrete and Steel, University Press, 2005.*
- Kubba D. Blue Print Reading: Construction Drawing for the Building Trade, McGraw Hill, 2008.*
- Marshall D. et al Understanding Housing Defects, 2nd edition, 2013.*
- Newton, P. Structural Detailing: for Architecture, Building and Civil Engineering 2nd edition, Macmillan Publisher, 1991.*

◆ UNIT 2A: MECHANICAL ENGINEERING DRAWING AND DESIGN

MODULE 1: MECHANICS OF MACHINES

GENERAL OBJECTIVES

On completion of this Module, students should develop:

1. a working knowledge of the characteristics of the operating principles of the mechanics of machines;
2. the ability to communicate, graphically and visually, the fundamentals of mechanics in different machine components using *conventional* and Computer Aided methods.

SPECIFIC OBJECTIVES

The students should be able to:

1. determine forces in structures using graphical methods;
2. construct shear force and bending moment diagrams in beams;
3. calculate the various parameters of the involute spur gears;
4. locate lines and planes in space;
5. *produce drawings using Computer-Aided Drafting (CAD) software.*

CONTENT

1. *Determining forces using graphical methods*

- (a) Triangle, parallelogram and polygon of forces to find:
 - (i) resultant equilibrium;
 - (ii) resolution of forces in members of simple framework.
- (b) Space and polar diagrams and funicular (link) polygons to find the position of the resultant or equilibrium.

2. *Shear force and bending moment diagrams in beams*

- (a) Types of beams:
 - (i) *simply supported:*
 - *with point load*

UNIT 2A

MODULE 1: MECHANICS OF MACHINES (cont'd)

- *with distributed load*
- (ii) *cantilever.*
- (b) Beam sign conventions.
- (c) *Shear Force Diagram (SFD) and Bending Moment Diagram (BMD) of beams.*

3. ***Involute Spur Gears***

- (a) Defining terms:
 - (i) pitch circle diameter;
 - (ii) pitch point;
 - (iii) pressure angle;
 - (iv) addendum;
 - (v) dedendum;
 - (vi) clearance;
 - (vii) circular pitch;
 - (viii) circular tooth thickness;
 - (ix) number of teeth;
 - (x) diametrical pitch;
 - (xi) module;
 - (xii) *base circle diameter;*
 - (xiii) *root diameter.*
- (b) Calculating parameters necessary to construct gear tooth profiles.
- (c) Construction of gear tooth profiles by involute and approximate methods.

UNIT 2A

MODULE 1: MECHANICS OF MACHINES (cont'd)

- (d) Construction of gear tooth in mesh.
- (e) Using ISO conventional systems and British Standards (BS 8888).

4. Lines and Planes in Space

- (a) True angles between intersecting lines.
- (b) True angles between intersecting planes.
- (c) True angles between lines and planes.
- (d) Traces of lines on planes.
- (e) Traces of planes on planes.
- (f) Traces of perpendicular planes and their inclination to the planes of reference.
- (g) Skewed lines.

5. Use of CAD software to produce drawings.

Suggested Teaching and Learning Activities

Teachers are encouraged to engage students in activities such as those listed below as they seek to achieve the objectives of this Module.

1. Use real life examples of components to illustrate the techniques contained in the Module.
2. Visit a Mechanical Engineering Drawing Office to familiarise students with the different conventional representation on drawings and the use and importance of drawing standards.
3. Have students research and deliver presentations on topics contained in the Module.

RESOURCES

Jackson, E. *Advanced Level Technical Drawing*, London: Metric Edition, Longman Group Limited, 1975.

Jensen C. Helsel, J., Short D. *Engineering Drawing and Design*: Madsen and Madsen, ISBN-13; 978-1-111-30966-4, ISBN-10; 1-111-30966-3, Delmar, Cengage Learning.

UNIT 2A

MODULE 2: ENGINEERING MATERIALS AND PROCESSES

GENERAL OBJECTIVES

On completion of this Module, students should:

1. *understand the structure, properties and manufacturing processes of engineering components;*
2. *develop a safe working knowledge of the uses, application and care of various types of engineering components.*

SPECIFIC OBJECTIVES

Students should be able to:

1. *select appropriate materials for the manufacturing of engineering components;*
2. *explain the appropriate manufacturing processes for various types of engineering components;*
3. *solve problems requiring knowledge of the application of bearings and bushings;*
4. *solve problems requiring knowledge of the application of seals and lubricants.*

CONTENT

1. Materials

(a) Metals:

- (i) ferrous (for example; wrought iron, cast iron, carbon steel, stainless steel);
- (ii) non-ferrous (for example; copper, aluminium, brass and other alloys).

(b) Plastics:

- (i) thermoplastic – polyvinyl chloride (PVC), polytetrafluoroethylene (fluorocarbons), polyethylene, polystyrene, polypropylene, polyamides (Nylon), polymethylmethacrylate (Perspex);
- (ii) thermosetting – epoxy-resin (bakelite, melamine), laminates (tufnol, formica).

UNIT 2A

MODULE 2: ENGINEERING MATERIALS AND PROCESSES (cont'd)

- (c) Rubber:
 - (i) characteristics (organic, silicone, synthetic);
 - (ii) uses and applications.

2. Manufacturing engineering components

- (a) Machining Tool Operations – turning, shaping, drilling, milling, cutting and grinding.
- (b) Casting – sand, die, investment.
- (c) Fabrication:
 - (i) welding – Shielded Metal Arc Welding (SMAW), Oxyfuel Gas Welding (OFW), Gas Tungsten-Arc Welding (GTAW or TIG), Gas Metal Arc Welding (GMAW or MIG), Laser Beam Welding (LBW), Resistance Spot Welding (RSW);
 - (ii) welding symbols and their application;
 - (iii) riveting – cold, hot, pop;
 - (iv) sheet metal work – grooved seam, rolling and bending.
- (d) Safety in Manufacturing:
 - (i) safety equipment and material;
 - (ii) safety procedures and processes in manufacturing;
 - (iii) designing for safety in manufacturing.

3. Solving problems with the application of bearings and bushings

- (a) Types of bearings and their functions:
 - (i) ball – radial, thrust, angular contact, self-aligning, single/double row;
 - (ii) roller – cylindrical (radial, thrust), tapered, spherical, needle;
 - (iii) journal – pillow block, self-lubricating.

UNIT 2A

MODULE 2: ENGINEERING MATERIALS AND PROCESSES (cont'd)

- (b) *Application of bearings in:*
 - (i) *rotational and linear movements;*
 - (ii) *handling stresses;*
 - (iii) *reduction of friction.*
- (c) *Application of bushings:*
 - (i) *Bush – drill, sleeve (tolerances);*
 - (ii) *reduction of friction;*
 - (iii) *reduction of wear;*
 - (iv) *mounting.*

4. Solving problems with the application of seals and lubricants

- (a) Types of seals and uses:
 - (i) static – gasket, o-ring;
 - (ii) dynamic – labyrinth, split ring, 'U', garter spring, o-ring.
- (b) Types of lubricants:
 - (i) liquid;
 - (ii) solid;
 - (iii) gas.
- (c) Methods of applications of lubricants:
 - (i) liquid – splash, pressurised;
 - (ii) solid;
 - (iii) gas (mist, air).

UNIT 2A

MODULE 2: ENGINEERING MATERIALS AND PROCESSES (cont'd)

Suggested Teaching and Learning Activities

Teachers are encouraged to engage students in activities such as those listed below as they seek to achieve the objectives of this Module.

1. Use real life examples of components made from the manufacturing processes and materials in Module.
2. Have students visit machine and mechanical engineering workshops to familiarise them with the various machine-tools, equipment and sub-assembly components being repaired.
3. Have students visit engineering plants/factories to observe the manufacture of components/products using the various processes and materials in the Module.
4. Have students research and make presentations on topics contained in the Module.
5. *Have students build actual models and produce CAD stimulations.*

RESOURCE

Jensen C. Helsel, J. and Short, D. *Engineering Drawing and Design: Madsen and Madsen*, ISBN-13; 978-1-111-30966-4, ISBN-10; 1-111-30966-3, Delmar, Cengage Learning.

UNIT 2A

MODULE 3: ENGINEERING DESIGN ELEMENTS

GENERAL OBJECTIVES

On completion of this Module, students should develop *skills to*:

1. *synthesise and modify designs using technical information and scientific principles;*
2. prepare freehand sketches and drawings of machine components suitable for different manufacturing processes.

SPECIFIC OBJECTIVES

Students should be able to:

1. solve problems requiring knowledge of various elements of power transmission;
2. prepare freehand sketches and drawings of machine components;
3. discuss the stages in the design process;
4. explain the principles of design;
5. *modify* designs of machine parts and components;
6. use CAD software to produce engineering drawings.

CONTENT

1. Solving problems using elements of power transmission

(a) Couplings:

- (i) rigid;
- (ii) flange;
- (iii) fluid;
- (iv) *oldham*;
- (v) *universal joint*;
- (vi) *cross and bearing*.

UNIT 2A

MODULE 3: ENGINEERING DESIGN ELEMENTS (cont'd)

(b) Clutches:

- (i) single plate;
- (ii) multi-plate;
- (iii) centrifugal.

(c) Gears:

- (i) spur;
- (ii) helical;
- (iii) bevel;
- (iv) worm.

(d) Belt drives:

- (i) vee;
- (ii) flat and toothed (tensioning of belts, fixed and movable shafts).

(e) Brakes:

- (i) single shoe;
- (ii) double shoe;
- (iii) internal drum disc.

(f) *Chain drives:*

- (i) *roller;*
- (ii) *inverted tooth/silent;*
- (iii) *tensioning of chain.*

UNIT 2A

MODULE 3: ENGINEERING DESIGN ELEMENTS (cont'd)

2. Preparing freehand sketches

- (a) *Machine components:*
 - (i) *fasteners;*
 - (ii) *locking devices;*
 - (iii) *keys, keyways, splines;*
 - (iv) *shaft coupling;*
 - (v) *bearings;*
 - (vi) *pistons, connecting rods and crankshafts;*
 - (vii) *hole preparations – countersink, counter bore.*

3. Stages in the design process

- (a) Recognition of need.
- (b) Definition of problem.
- (c) Synthesis.
- (d) Analysis and optimisation.
- (e) Evaluation.
- (f) Presentation.

4. The design principles

- (a) Elements:
 - (i) materials specification;
 - (ii) manufacturing processes;
 - (iii) size and shape.
- (b) Aesthetics.
- (c) Ergonomics
 - *human machine relationships for example, control loops, mouse.*

UNIT 2A

MODULE 3: ENGINEERING DESIGN ELEMENTS (cont'd)

(d) Cost.

5. Creating and modifying design details

Design for:

(a) Casting.

(b) Machining.

(c) Fabrication.

6. *Using CAD Software to produce engineering components.*

Suggested Teaching and Learning Activities

Teachers are encouraged to engage students in activities such as those listed below as they seek to achieve the objectives of this Module.

1. Use articles from current periodical on relevant Mechanical Engineering topics to assist students in adequately covering the content in the Module.
2. Have students complete a number of working and assembly drawings of various engineering components.
3. Place emphasis on the importance of freehand sketching to enable students to become familiar with the differences in the theory and construction of various devices.
4. Have students visit a Mechanical Engineering Drawing Office to familiarise them with the different conventional representation on drawings and the use and importance of drawing standards.
5. *Arrange guest lectures.*
6. *Have students build actual models and produce CAD stimulations.*

RESOURCE

Jensen C. Helsel, J. and Short, D. *Engineering Drawing and Design: Madsen and Madsen, ISBN-13; 978-1-111-30966-4, ISBN-10; 1-111-30966-3, Delmar, Cengage Learning.*

◆ **UNIT 2B: BUILDING DRAWING AND DESIGN**

MODULE 1: STRUCTURAL DRAWINGS

GENERAL OBJECTIVES

On completion of this Module, student should develop:

- 1. a working knowledge of the principles underlying the design and preparation of different types of structural drawings using conventional and CAD methods;*
- 2. the ability to design structural drawing plans and layouts of various types of timber, concrete and steel structures in accordance with structural building codes.*

SPECIFIC OBJECTIVES

Students should be able to:

- 1. determine forces in structures using graphical methods;*
- 2. construct shear force and bending moment diagrams in beams;*
- 3. create detailed free hand sketches of structural drawings;*
- 4. produce a complete set of structural drawings using suitable scales.*

CONTENT

1. Determining forces using graphical methods

(a) *Triangle, parallelogram and polygon of forces to find:*

(i) *resultant equilibrium;*

(ii) *resolution of forces in members of simple framework.*

(b) *Space and polar diagrams and funicular (link) polygons to find the position of resultant or equilibrium.*

2. Constructing shear force and bending moment diagrams in beams

(a) *Types of beams:*

(i) *simply supported;*

UNIT 2B

MODULE 1: STRUCTURAL DRAWINGS (cont'd)

- (ii) *cantilever;*
- (iii) *overhanging;*
- (iv) *continuous.*
- (b) *Beam sign conventions.*
- (c) *Shear force diagram (SFD) and bending moment (BMD) of beams.*

3. Detailed sketches

- (a) *Auger Pile plan with grid lines:*
 - (i) *auger pile plan layout;*
 - (ii) *detail section through pile foundation.*
- (b) *Column plan with grid lines:*
 - (i) *column plan layout with grid lines;*
 - (ii) *column detail;*
 - (iii) *section through column.*

4. Producing and reproducing structural drawings

- (a) *Beam and column plan:*
 - (i) *structural beam framing plan layout;*
 - (ii) *Structural details of each beam.*
- (b) *Reinforced concrete plan:*
 - (i) *first floor slab plan;*
 - (ii) *sectional drawing through reinforced concrete first floor slab.*

UNIT 2B

MODULE 1: STRUCTURAL DRAWINGS (cont'd)

- (c) *Roof Plan:*
 - (i) *gable;*
 - (ii) *hip;*
 - (iii) *bow string;*
 - (iv) *reinforced concrete roof slab.*

- (d) *Structural connection details:*
 - (i) *corner wall stiffeners detail;*
 - (ii) *corner junctions (L and T) wall stiffener details;*
 - (iii) *details of ground, lintel and ring beams;*
 - (iv) *box drain and slipper drain.*

- (e) *Septic tank and soak-a-way pit details:*
 - (i) *plan of septic tank and soak-a-way pit;*
 - (ii) *sectional elevation through septic tank and soak away pit.*

- (f) *Staircase Layout:*
 - (i) *straight flight:*
 - *with landing*
 - (ii) *'U' Shape;*
 - (iii) *L flight;*
 - (iv) *spiral.*

- (g) *Wooden structures*
Structures:
 - (i) *floors;*
 - (ii) *ceiling;*
 - (iii) *walls.*

UNIT 2B

MODULE 1: STRUCTURAL DRAWINGS (cont'd)

Suggested Teaching and Learning Activities

Teachers are encouraged to engage students in activities such as those listed below as they seek to achieve the objectives of this Module.

1. Use articles from current periodical on relevant architectural drawing topics to assist students in adequately covering the content in the Module.
2. Have students complete a number of working and assembly drawings of various structural components.
3. Place emphasis on the importance of sketching to enable students to become familiar with the differences in the theory and construction of building structures.

RESOURCES

- Chudley, R. and Green, R. *Construction Technology, 4th edition, Essex: Pearson Prentice Hall, 2005.*
- Krishna, N. *Structural Design and Drawing: Reinforced Concrete and Steel, University Press, 2005*
- Kubba, D. *Blue Print Reading: Construction Drawing for the Building Trade, McGraw Hill, 2008*
- Marshall, D. et al *Understanding Housing Defects, 2nd edition , 2013*
- Newton, P. *Structural Detailing: for Architecture, Building and Civil Engineering 2nd edition, Macmillan Publisher, 1991.*

UNIT 2B

MODULE 2: BUILDING MATERIALS AND PROCESSES

GENERAL OBJECTIVES

On completion of this module, students should:

- 1. understand the uses, production and characteristics of construction materials to satisfy specifications of construction processes in building designs;*
- 2. develop an awareness of the processes and equipment used in the application of building materials;*
- 3. understand the fundamental principles of construction management.*

SPECIFIC OBJECTIVES

The students should be able to:

- 1. discuss the use of various types of construction materials;*
- 2. discuss common properties associated with building construction materials;*
- 3. analyse the properties of different types of building construction materials;*
- 4. outline the processes involved in the production of common building construction materials;*
- 5. select suitable materials and their symbols for use in the design of different building structures;*
- 6. use of common construction equipment and hand tools;*

CONTENT

- 1. Use of various types of construction materials**
 - (a) Sand.*
 - (b) Bricks.*

UNIT 2B

MODULE 2: BUILDING MATERIALS AND PROCESSES (cont'd)

- (i) *common;*
 - (ii) *facing;*
 - (iii) *engineering.*
- (c) *Blocks:*
 - (i) *concrete;*
 - (ii) *stone;*
 - (iii) *clay.*
- (d) *Timber.*
- (e) *Paint:*
 - (i) *solvent;*
 - (ii) *primer;*
 - (iii) *undercoat;*
 - (iv) *finishing;*
 - (v) *rubberised;*
 - (vi) *rust proofing.*
- (f) *Plastics:*
 - (i) *thermoplastics, for example, conduits, drain, waste, vents, sidings;*
 - (ii) *thermosets, for example, laminates, electrical fixtures.*
- (g) *Glass.*
- (h) *Cement:*
 - (i) *ordinary Portland cement (OPC);*
 - (ii) *relative humidity Portland cement (RHPC);*
 - (iii) *sulfate resistant Portland cement (SRPC);*
 - (iv) *coloured Portland cement.*

UNIT 2B

MODULE 2: BUILDING MATERIALS AND PROCESSES (cont'd)

- (i) *Aggregates.*
- (j) *Concrete.*
- (k) *Plaster.*
- (l) *Steel.*
- (m) *Tiles.*
- (n) *Rubber.*

2. Common properties of construction materials

Definitions and characteristics:

- (a) *thermal expansion;*
- (b) *thermal conductivity;*
- (c) *heat movement and heat flow;*
- (d) *insulation (High and low U factors);*
- (e) *thermal resistance;*
- (f) *strength and stress;*
- (g) *deformation;*
- (h) *strain;*
- (i) *creep;*
- (j) *elasticity and plasticity.*

3. Analysing the properties of construction materials

Types and testing procedures and findings of:

- (a) *concrete (stressed and pre-stressed);*
- (b) *cement;*

UNIT 2B

MODULE 2: BUILDING MATERIALS AND PROCESSES (cont'd)

(c) sand;

(d) concrete blocks;

(e) steel.

4. Common construction processes

(a) Preparing and applying concrete.

(b) Rendering/plastering.

(c) Plumbing.

(d) Electrical wiring.

(e) Landscaping.

5. Selecting materials

Building structures:

(a) footing walls;

(b) floors;

(c) ceilings;

(d) external walls;

(e) partition/internal walls;

(f) roofs.

6. Using construction equipment and hand tools.

Processes:

(a) preparing and applying concrete;

(b) rendering/plastering;

(c) screeding.

UNIT 2B

MODULE 2: BUILDING MATERIALS AND PROCESSES (cont'd)

Suggested Teaching and Learning Activities

Teachers are encouraged to engage students in activities such as those listed below as they seek to achieve the objectives of this Module.

1. *Use real life examples of components made from the manufacturing processes and materials in Module.*
2. *Have students visit a manufacturing plant and/or hardware store to familiarise them with the various tools, equipment and processes.*

UNIT 2B

MODULE 2: BUILDING MATERIALS AND PROCESSES (cont'd)

3. *Have students research and make presentations on topics contained in the Module.*
4. *Invite guest lecturer.*

RESOURCES

- Chudley, R. and Green, R. *Construction Technology, 4th edition, Essex: Pearson Prentice Hall, 2005.*
- Allen, E. and Joseph I. *Fundamentals of Building Construction: Materials and Methods, John Wiley & Sons, 2011.*
- Marotta, T. *Basic Construction materials, Methods and Testing, Prentice Hall, 1992.*

UNIT 2B

MODULE 3: MANAGEMENT AND DESIGN

GENERAL OBJECTIVES

On completion of this Module, students should develop the skills to:

- 1. synthesise and modify designs using creativity, technical information and scientific principles;*
- 2. prepare sketches and drawings of building designs using CAD.*

SPECIFIC OBJECTIVES

Students should be able to:

- 1. discuss the basic principles of construction management;*
- 2. explain the principles of design;*
- 3. prepare sketches of external and internal design features of buildings;*
- 4. use CAD to produce designs of buildings.*

CONTENT

1. Construction Management

(a) *Management techniques relating to:*

- (i) production planning;*
- (ii) cost control of projects;*
- (iii) principles of planning repetitive and non-repetitive construction work.*

(b) *Planning techniques:*

- (i) bar charts;*
- (ii) network analysis;*
- (iii) line of balance;*

UNIT 2B

MODULE 3: MANAGEMENT AND DESIGN (cont'd)

- (iv) *work study.*
- (c) *Plant decision making:*
 - (i) *plant selection;*
 - (ii) *plant acquisition (buying, leasing, indirect or direct ownership);*
 - (iii) *developing and classifying objectives;*
 - (iv) *establishing alternatives choices;*
 - (v) *evaluating the outcome of each alternative;*
 - (vi) *choosing the best alternative.*

2. Stages in the design process

- (a) *Recognition of need.*
- (b) *Definition of problem.*
- (c) *Synthesis.*
- (d) *Analysis and optimisation.*
- (e) *Evaluation.*
- (f) *Presentation.*

3. The design principles

- (a) *Elements:*
 - (i) *materials specification;*
 - (ii) *manufacturing processes;*
 - (iii) *size and shape.*
- (b) *Aesthetics.*
- (c) *Ergonomics.*
- (d) *Cost.*

UNIT 2B

MODULE 3: MANAGEMENT AND DESIGN (cont'd)

4. Design features of buildings

(a) *External wall finishes:*

- (i) *trowel plastering;*
- (ii) *tile (ceramic, marble, clay, coral);*
- (iii) *cladding (metal);*
- (iv) *paint.*

(b) *Internal wall finishes:*

- (i) *paint;*
- (ii) *cladding;*
- (iii) *tiles (ceramic, marble, porcelain).*

(c) *Floor finishes:*

- (i) *tiles (ceramic, marble, clay, porcelain, vinyl);*
- (ii) *hard wood (teak, mahogany, green heart);*
- (iii) *terrazzo.*

(d) *Doors and windows (internal and external):*

- (i) *wooden (teak, mahogany, green heart);*
- (ii) *glass;*
- (iii) *metal (steel, zinc, aluminium).*

(e) *Cupboard:*

- (i) *wooden, for example, teak, mahogany, green heart, plywood, Medium density Fibre Board (MDF), pine;*
- (ii) *concrete (block work).*

UNIT 2B

MODULE 3: MANAGEMENT AND DESIGN (cont'd)

Fixtures and fittings:

- (i) bathroom, for example, face basin, water closet, shower enclosure, shower taps, faucet;*
- (ii) kitchen (kitchen sinks, faucet).*

(a) Electrical Fittings:

- (i) lighting fixtures;*
- (ii) electrical panel and power outlets;*
- (iii) switches;*
- (iv) auxiliary outlets, for example, television and networking cable.*

(b) Counter top finishes:

- (i) ceramics;*
- (ii) porcelain;*
- (iii) hard wood;*
- (iv) synthetic surfaces;*
- (v) granite.*

(c) Landscaping:

- (i) lawn, flower bed;*
- (ii) driveway;*
- (iii) walkway;*
- (iv) rock garden.*

(d) Sick Building Syndrome (SBS).

UNIT 2B

MODULE 3: MANAGEMENT AND DESIGN (cont'd)

5. Using CAD software

- (a) Full set of working drawings for two-storey building.
- (b) Rendering and finishes.

Suggested Teaching and Learning Activities

Teachers are encouraged to engage students in activities such as those listed below as they seek to achieve the objectives of this Module.

1. Organise teams to study design features in the school and community and to solve design problems.
2. Have students visit construction sites to observe the utilisation of components/products.
3. Have students research and make presentations on topics contained in the Module.
4. Invite guest lecturers.
5. Use audio/visual aids to enhance learning.

RESOURCE

Chudley, R. and Green, R. *Construction Technology, 4th edition, Essex: Pearson Prentice Hall, 2005.*

◆ OUTLINE OF ASSESSMENT

Each Unit of the syllabus will be independently assessed and graded separately. Candidates have the option of submitting their responses to Paper 02 using either the traditional drawing method (drawing board and tee square) or Computer-Aided Drafting (CAD) software.

EXTERNAL ASSESSMENT

(70%)

Written Papers

Paper 01

(1 hour 30 Minutes)

Unit 1

30%

This paper will consist of 45 multiple-choice items, 15 items based on each of the three Modules in the Unit. All items are compulsory. To accommodate the option of either Module 3A or 3B, there will be two papers. Both papers will consist of 15 items from Modules 1 and 2 each and 15 items from either Module 3A or 3B.

(1 hour 30 Minutes)

Unit 2

Option A and Option B

The paper tests options A and B separately and consists of 45 multiple choice items, 15 items based on each of the three Modules in the Unit.

Paper 02

(2 hours 30 Minutes)

Unit 1

40%

Eight extended response questions arranged in four sections A, B, C and D.

Sections A, B, C and D each comprise two questions. Section A tests Module 1; Section B tests Module 2; Section C tests Option A in Module 3; and Section D tests Option B in Module 3

Candidates will be required to answer All questions from Sections A and B and ALL questions from either Section C or Section D.

Unit 2

Option A and Option B.

For each Option: Six extended response questions arranged in three sections: A, B and C.

In both Options, Sections A, B and C each comprise two questions. Section A tests Module 1; Section B tests Module 2; and Section C tests Module 3.

Candidates will be required to answer ALL questions from each section.

Paper 03

The SBA for Unit 1 is derived from the composite marks of the entries in the School-Based Assessment portfolio and which may include related CVQ Units of Competency aligned to the content in the syllabus. Candidates must complete selected Units in the CVQ Regional Occupational Standards to obtain the Unit certification.

The SBA for Unit 2 is derived from the composite marks of entries in the School-Based Assessment portfolio and may also include related CVQ Units aligned to the content in the syllabus for certification. Candidates must complete selected Units in the CVQ Regional Occupational Standards to obtain the Unit certification.

ASSESSMENT DETAILS

Each Unit will be assessed as follows:

External Assessment by Written Papers - (70 per cent of Total Assessment)**Paper 01 (1 1/2 hours – 30 per cent of Total Assessment)****1. Composition of the Paper****Unit 1**

This paper consists of 45 multiple-choice items on all Modules as follows:

To accommodate the option between 3A and 3B, there will be two papers. Each paper will have fifteen similar items each from Module 1 and Module 2 and fifteen items from either Module 3A (Engineering Drawing) or 3B (Building Drawing). All questions are compulsory.

Unit 2

This paper consists of 45 multiple-choice items on all Modules as follows:

Option A (Mechanical Engineering) and Option B (Building Drawing) will each consist of 45 multiple-choice items; 15 items from each Module. All questions are compulsory.

The percentage weighting of the profile dimensions is as follows:

Knowledge	-	22
Application	-	34
Practical Ability	-	44

The percentage weighting of the examination components is as follows:

Paper 01 - 30
Paper 02 - 40

Paper 03 (SBA) - 30

2. Mark Allocation

This paper is worth 45 marks and contributes 30 per cent towards the final assessment. Each Module is worth 15 marks and contributes 10 per cent towards the final assessment.

3. Use of Calculators

Candidates may use silent, non-programmable calculators.

Paper 02 (2 1/2 hours - 40% of Total Assessment)

1. Composition of Paper

Unit 1

This paper consists of eight questions in four sections, A, B, C and D. Each section contains two questions. Section A tests Module 1; Section B tests Module 2; Section C tests Module 3 Option A; and Section D tests Module 3 Option B. The candidate is required to answer ALL questions from Section A, Module 1 and Section B Module 2 and ALL questions from **either** section C, Module 3A **or** Section D, Module 3B.

Unit 2

For each option in the Unit, Paper 02 is divided into three sections, A, B and C, each representing one of the three Modules. Each section contains two questions. The candidate is required to answer ALL questions from each of the three sections.

All questions are equally weighted and may require knowledge of more than one topic in the Module from which they are taken.

2. Mark Allocation

This paper is worth 120 marks and contributes 40 per cent towards the final assessment. Each Module is worth 40 marks and contributes approximately 13.3 per cent towards the final assessment. Each question is worth 20 marks.

3. Award of Marks

Full marks will be awarded for correct answers supported by relevant working or demonstration of the process.

No marks will be awarded to a correct answer which is unsupported by any details of the method used (for example: calculations, construction or line-work). Candidates are,

therefore, advised to show **all** their working.

4. Use of Calculators

Candidates may use silent, non-programmable calculators.

SCHOOL-BASED ASSESSMENT (30 per cent of Total Assessment)

Internal Assessment is an integral part of student assessment in the course covered by this syllabus. It is intended to assist students in acquiring certain knowledge, skills and attitudes that are associated with the subject. The activities for the Internal Assessment are linked to the syllabus and should form part of the learning activities to enable the student to achieve the objectives of the syllabus.

During the course of study for the subject, students obtain marks for the competence they develop and demonstrate in undertaking their Internal Assessment assignments. These marks contribute to the final marks and grades that are awarded to students for their performance in the examination.

The guidelines provided in this syllabus for selecting appropriate tasks are intended to assist teachers and students in selecting assignments that are valid for the purpose of School-Based Assessment. The guidelines provided for the assessment of the assignments are intended to assist teachers in awarding marks that are reliable estimates of the achievement of students in the School-Based Assessment component of the course. In order to ensure that the scores awarded by teachers are in line with the Caribbean Examinations Council's standards, the Council undertakes the moderation of a sample of the Internal Assessment assignments marked by each teacher. Internal Assessment provides an opportunity to individualise a part of the curriculum to meet the needs of students. It facilitates feedback to the student at various stages of the experience. This helps to build the self-confidence of students as they proceed with their studies. Schools-Based Assessment also facilitates the development of the critical skills and abilities emphasised by this CAPE subject and enhances the validity of the examination on which candidate performance is reported. Internal Assessment, therefore, makes a significant and unique contribution to both the development of relevant skills and the testing and rewarding of students for the development of those skills.

The Caribbean Examinations Council seeks to ensure that the School-Based Assessment scores are valid and reliable estimates of accomplishment. The guidelines provided in this syllabus are intended to assist in doing so.

The School-Based Assessment will consist of a Portfolio for each Unit consisting of assignments taken from the Module(s) outlined in the syllabus.

UNIT 1

Paper 031 - Drawing Portfolio (30 per cent of the Total Assessment)

Composition

*The Drawing Portfolio must consist of six assignments. Two assignments must be set on each Module. **At least one assignment from each Module must be CAD-based.** A complete record of freehand sketches and final drawing solutions must be submitted in the Drawing Portfolio. The assignments in each Portfolio will be assessed by the teacher and a sample of the Portfolios will be*

reassessed by a moderator appointed by CXC.

Mark Allocation

Each assignment is worth 20 marks and is marked using the criteria and mark schemes for School-Based Assessment assignments outlined on pages 53-56 of the syllabus.

The mark recorded for each Module will be the average of the TWO Module assignments. **The Internal Assessment for each Module is compulsory and failure to submit all assignments will normally result in no marks being awarded for Internal Assessment.** Assignments are set and assessed by the teacher, using the Internal Assessment Assignments, Criteria and Mark Schemes provided on pages 53-56 of the syllabus.

UNIT 1

SCHOOL-BASED ASSESSMENT ASSIGNMENTS, CRITERIA AND MARK SCHEMES

Assignments

Each candidate is required to produce a Drawing Portfolio consisting of six original drawings. Examples of appropriate sources and topics on which these assignments may be based are given below.

For **EACH** assignment the student will submit a completed drawing or set of drawings on A2 (420 x 594 mm) paper by itself with border lines and title block.

Candidates pursuing Option 3A (Engineering Drawing) will complete the following SBA Assignments:

Assignment 1

Candidates will be expected to produce drawings based on Specific Objectives 1 and 2 of Module 1.

Assignment 2

Candidates will be expected to produce ONE drawing based on Specific Objectives 3 and 4 of Module 1.

Assignment 3

Candidates will be expected to produce ONE drawing based on Specific Objectives 2 to 5 of Module 2.

Assignment 4

Candidates will be expected to produce ONE drawing using CAD software and based on Specific Objective 6 of Module 2.

Assignment 5

Candidates will be expected to produce drawings based on Specific Objectives 1, 2 and 3 of Module 3A.

Assignment 6

Candidates will be expected to produce ONE drawing based on Specific Objectives 4, 5 and 6 of Module 3A.

Candidates pursuing Option 3B (Building Drawing) will complete the following SBA Assignments:

Assignment 1

Candidates will be expected to produce drawings based on Specific Objectives 1 and 2 of Module 1.

Assignment 2

Candidates will be expected to produce ONE drawing based on Specific Objectives 3 and 4 of Module 1.

Assignment 3

Candidates will be expected to produce ONE drawing based on Specific Objectives 2 to 5 of Module 2.

Assignment 4

Candidates will be expected to produce ONE drawing using CAD software and based on Specific Objective 6 of Module 2.

Assignment 5

Candidates will be expected to produce drawings based on Specific Objectives 1 of Module 3B.

Assignment 6

Candidates will be expected to produce ONE drawing based on Specific Objectives 2, 3 and 4 of Module 3B.

Mark Scheme for Assignments 1, 2, 3, 5 and 6

Teachers should allocate marks as shown in the table below.

CRITERIA	MARKS	TOTAL MARKS
1. Construction of lines and curves to form components (showing construction line where appropriate). - More than 90% accurate - More than 80% accurate - More than 70% accurate - More than 60% accurate	4 3 2 1	4
2. Use of line types, centre lines dimensions as needed (Balloon referencing and parts listing, hatching lines). - More than 95% accurate - More than 90% accurate - More than 85% accurate - More than 80% accurate - More than 70% accurate - More than 60% accurate	6 5 4 3 2 1	6
3. Accuracy of components drawn from given objects, sketches or drawings. - More than 95% accurate - More than 90% accurate - More than 85% accurate - More than 80% accurate - More than 70% accurate - More than 60% accurate	6 5 4 3 2 1	6
4. Linework - Neat - Clean	1 1	2
5. Completion of drawings - Title blocks completed - Border lines completed	1 1	2
TOTAL		20

Mark Scheme for Assignment 4

The student will submit:

1. a list of the commands used for a given set of tasks on a separate sheet;
2. a complete drawing on A4 (210 x 297 mm) paper from a given sketch or drawing;
3. a labelled diskette with the completed drawing and commands.

Teachers will allocate marks as shown in the table below.

CRITERIA	MARKS	TOTAL MARKS
1. Use of commands - More than 90% accurate - More than 80% accurate - More than 70% accurate - More than 60% accurate	4 3 2 1	4
2. Production of drawing using CAD software - drawing (point on node) - line size - line types - scales - dimensions - notations For each of the features in the list above award marks as follows to a maximum of 2 marks for each feature: - more than 90% accurate - 70 – 89% accurate - drawing - more than 90% completed - 70 – 89% completed - title block - border lines	2 1 2 1 1 1	16
TOTAL		20

General

1. Teachers should inform candidates of the assessment criteria.
2. Teachers should guide the candidates in choosing appropriate assignments that relate to the candidates' interest and specific objectives identified.

3. Teachers and candidates should agree to a schedule of the dates for submitting assignments.
4. The teacher should offer guidance in the process and the preparation of the portfolio.

Management of Drawing Portfolio

Teachers should encourage students to start the first assignment during the first term and to complete an assignment once every five weeks.

UNIT 2

Paper 03/1 – Design Portfolio

Composition

The Design Portfolio must consist of three phases leading to the final design solution, namely:

- (i) Phase 1 – Conceptualisation of the project;
- (ii) Phase 2 – Design of project;
- (iii) Phase 3 – Work programme (methodology, resources, schedule).

Students will be assessed on completed assignments at each phase. **The Design Portfolio must be CAD-based, with evidence of the acquisition of knowledge and skills gained at each phase.** A complete record of the proposal, pictorial and working drawings, freehand sketches, specifications, calculations and final design solution should be kept in the Design Portfolio. The Design Portfolio will be assessed by the teacher and a sample of the documents will be reassessed by a moderator appointed by CXC.

Each student must prepare a technical report on the project and make a presentation of his/her final design solution in class. Teachers are encouraged to use experts in the fields of mechanical engineering and architectural design to provide feedback on candidates' work.

Mark Allocation

There is one assignment in the Design Portfolio which is worth 60 marks. These marks will be awarded based on the criteria listed below (see pages 56-61 for detailed breakdown of Assessment Criteria).

<u>Assessment Criteria</u>	<u>Marks</u>
(i) Development of Project	22
• Phase 1 – Conceptualisation of the Project	(06)
• Phase 2 - Design of Project	(10)
• Phase 3 – Work programme (methodology, resources schedule)	(06)
(ii) *Use of CAD	06
(iii) The Project Report	16

(iv)	Contents of Portfolio	08
(v)	The Interactive Presentation	08

(*Commands used and electronic copy of final drawings must be submitted)

SCHOOL-BASED ASSESSMENT CRITERIA AND MARK SCHEMES

Project, Design Portfolio and Interactive Presentation

Candidates will be awarded a total of six marks for communicating information in a logical way using correct grammar.

The assessment of the Design Portfolio must be done by the teacher. The Assessment Criteria provided below are intended to assist teachers in awarding marks that are reliable assessments of the achievement of students on the design project they select. These assessments should be submitted to CXC.

	Assessment Criteria	Range of Marks	Total Marks
1	<p>Development of Project</p> <p><i>Phase 1 – Conceptualisation of Project</i></p> <p><i>In this phase, students are expected seek the guidance of their teachers and engage in research that <u>will inform</u> the conceptualisation of the Project.</i></p> <ul style="list-style-type: none"> - Good <ul style="list-style-type: none"> - <i>Demonstrated a comprehensive understanding and good insight of concept(s)</i> - <i>Demonstrated keen interest for the task</i> - <i>Gathered relevant information (90%) from appropriate sources</i> - <i>Required minimal supervision to complete complex and routine tasks</i> - Satisfactory <ul style="list-style-type: none"> - <i>Demonstrated a satisfactory understanding of the concept(s)</i> - <i>Demonstrated interest in the task</i> - <i>Gathered relevant information (70%) from appropriate sources</i> - <i>Required some supervision to complete complex tasks but not the routine tasks</i> - Limited <ul style="list-style-type: none"> - <i>Demonstrated a limited understanding of the concept(s)</i> - <i>Demonstrated limited interest in the task</i> - <i>Gathered irrelevant information (>50%)</i> - <i>Main source of information inappropriate</i> - <i>Unable to complete routine tasks without supervision</i> 	<p>(6)</p> <p>5 - 6</p> <p>3 - 4</p> <p>1 - 2</p>	22

Assessment Criteria	Range of Marks	Total Marks
<p><i>Phase 2 – Design of Project</i></p> <p><i>In this practical phase, students are expected to work closely with their teachers to complete a) to e) for their Projects.</i></p> <p><i>The design must include:</i></p> <ul style="list-style-type: none"> <i>(a) sketches of preliminary and final design solutions</i> <i>(b) detailed working drawings</i> <i>(c) assembly drawings</i> <i>(d) application of theories explored in Phase 1</i> <i>(e) the specifications of the component(s) in the Project</i> <ul style="list-style-type: none"> - Good: <i>Sketches and drawings for more than THREE different design solutions presented. Strong link between the theories explored in Phase 1 and details in sketches and drawings of the chosen design. Good rationale for the chosen specifications.</i> - Satisfactory: <i>Sketches and drawings for THREE different design solutions presented. Satisfactory link between the theories explored in Phase 1 and details in the sketches and drawings of the chosen design. Satisfactory rationale for the chosen specifications.</i> - Limited: <i>Sketches and drawings for less than THREE different design solutions presented. A moderate link between the theories explored in Phase 1 and details in the sketches and drawings of the chosen design. Fair rationale for the chosen specifications.</i> 	<p>(10)</p> <p>7 - 10</p> <p>4 - 6</p> <p>0 - 3</p>	

Assessment Criteria		Range of Marks	Total Marks
<i>Phase 3 – Work Programme</i>		(06)	
<p><i>This report must include:</i></p> <ul style="list-style-type: none"> <i>a) statement of approach or methodology</i> <i>b) resources, including software, equipment and literature used</i> <i>c) scheduling of tasks for each Phase</i> <ul style="list-style-type: none"> • Good: <i>Used appropriate methodology and resources. <u>Most</u> tasks completed and schedule indicates an efficient use of time.</i> • Satisfactory: <i>Used appropriate methodology. <u>Many</u> tasks (60%) completed and suitable resources were used. Schedule indicates a satisfactory use of time.</i> • Fair: <i>Inappropriate use of methodology and/or most resources. There were many incomplete tasks and/or the schedule was loosely organised.</i> 		<p>5 – 6</p> <p>3 – 4</p> <p>0 – 2</p>	
2	Use of CAD Software		06
	<ul style="list-style-type: none"> • Good: <i>ALL (>90%) drawings completed with accurate representations of the components and correct use of commands.</i> • Satisfactory: <i>MANY (>75%) drawings completed with accurate representations of MANY of the components with minor errors in the use of commands.</i> • Limited: <i>FEW (>60%) drawings completed with major inaccuracies in the representations of the components and use of commands.</i> 	<p>5 – 6</p> <p>3 – 4</p> <p>1 – 2</p>	

Assessment Criteria		Range of Marks	Total Marks
3	The Project Report		16
	(a) <i>Project proposal (statement of purpose or definition of problem).</i>	(03)	
	- <i>Concise, aligned with the design problem</i>	3	
	- <i>Loose or ambiguous alignment with the design problem</i>	1-2	
	(b) <i>Statement of project scope and specifications</i>	(02)	
	- <i>Statement is relevant to project theme/title, specifications unambiguous</i>	2	
	- <i>Statement is generally relevant to project theme/title some ambiguity in specifications</i>	1	
	(c) <i>Constraints and limitations</i>	(02)	
	- <i>Satisfactory insight in the identification of problem-solving strategies</i>	2	
	- <i>Limited insight in the identification of problem-solving strategies</i>	1	
(d) <i>Final design of project (freehand sketches, detailed working drawing, assembly drawing, specifications)</i>	(04)		
- <i>Satisfactory match of products with specifications outlined in the project scope</i>	3 – 4		
- <i>Limited match of products with specifications outlined in the project scope</i>	1 – 2		
(e) <i>Communication of information in a logical way</i>	(05)		
• <i>communicates information in a logical way using correct grammar and appropriate terminology of the field MOST of the time</i>	4 – 5		
• <i>communicates information in a logical way using correct grammar and appropriate terminology of the field SOME of the time</i>	2 – 3		
• <i>communicates information in a logical way RARELY using correct grammar and appropriate terminology of the field.</i>	0 – 1		
4	Contents of Portfolio		08
	• Good: <i>Contents were neatly organised, containing relevant materials for the task.</i>	6 – 8	
	• Satisfactory: <i>Contents were generally neat and organised and/or most of the materials were relevant for the task.</i>	3 – 5	
	• Limited: <i>Contents were loosely organised and/or contained many irrelevant materials for the task.</i>	0 - 2	

Assessment Criteria		Range of Marks	Total Marks
5	<i>The Interactive Presentation</i>		08
	<ul style="list-style-type: none"> • <i>Quality of presentation</i> <ul style="list-style-type: none"> - <i>Logical sequence of ideas in presentation, student demonstrates full knowledge of the topic by answering questions with explanations and elaboration</i> - <i>Explanation needed to follow the sequence of ideas in presentation student demonstrates knowledge of most aspects of the topic and answered the rudimentary questions.</i> - <i>Sequence of ideas erratic and difficult to follow student was unable to answer many of the questions related to the topic</i> • <i>Use of computer-aided material</i> <ul style="list-style-type: none"> - <i>Generally relevant to concepts</i> - <i>Moderately relevant to concepts</i> • <i>Communication of Information(vocabulary, grammar)</i> <ul style="list-style-type: none"> - <i>Presented ideas using appropriate terminology and generally correct grammar</i> 	<p>(05) 4 - 5</p> <p>2 – 3</p> <p>0 - 1</p> <p>(02) 2 1</p> <p>(01) 1</p>	
Total			60

◆ REGULATIONS FOR PRIVATE CANDIDATES

Candidates who are registered privately will be required to sit Paper 01, Paper 02 and Paper 03. Detailed information on Papers 01, 02 and 03 is given on pages 47–50 of this syllabus.

◆ REGULATIONS FOR RESIT CANDIDATES

Resit candidates must complete Papers 01 and 02 and Paper 03/1 of the examination for the year for which they re-register. Resit candidates may elect not to repeat the School-Based Assessment component, provided they rewrite the examination no later than two years following their first attempt.

A candidate who rewrites the examination in the same Unit within two years may opt to complete a School-Based Assessment for each Unit written or may opt to reuse the moderated SBA score earned in the previous sitting within the preceding two years. Candidates reusing SBA scores in this way must register as “Resit candidates” and provide the previous candidate number. Candidates are no longer required to earn a moderated score that is at least 50 per cent of the maximum possible score; any moderated score may be reused.

Resit candidates must be entered through a school, a recognised educational institution, or the Local Registrar’s Office.

◆ ASSESSMENT GRID

The Assessment Grid for each Unit contains marks assigned to each paper and to each Module and the percentage contribution of each paper to total scores.

PAPERS	MODULES			TOTAL (WEIGHTED)	(%)
	<i>Module 1</i>	<i>Module 2</i>	<i>Module 3</i>		
<i>External Assessment Paper 01</i>	15 (30)	15 (30)	15 (30)	45 (90)	(30)
<i>Paper 02</i>	40	40	40	120	(40)
<i>Unit 1 School-based Assessment Paper 03/1</i>	40 (30)	40 (30)	40 (30)	120 (90)	(30)
<i>Unit 2 School-based Assessment Paper 03/1</i>	20 (30)	20 (30)	20 (30)	60 (90)	
Total	100	100	100	300	(100)

◆ REFERENCE MATERIAL

British Standards Institutions, *Engineering Drawing Practice for Schools and Colleges*, London: British Standards Institution, 1986.

BS 4500A, *Selected ISO Fits – Hole Basis*.

BS 4500B, *Selected ISO Fits – Shaft Basis*.

Brown, W. C.

Drafting for Industry, Illinois: Goodhart Wilcox, 1994.

House, R

Using AutoCAD 2000, Indianapolis: The Macmillian Press, 2000.

McLain, K.J

Designers AutoCAD 2000 Tutorial, Ohio: Thompson Learning Company 2001.

Simmons, C. and Maguire, D.

A Manual of Engineering Drawing, London: Hodder and Stoughton, 1995.

Yarwood, A.

Introduction to AutoCAD 2000, London: Longmans, 1999.

◆ MINIMUM EQUIPMENT LIST

(For Every 15 Students)

EQUIPMENT/MATERIAL	DESCRIPTION/SPECIFICATION	QUANTITY
Drawing Room	With proper lighting	1
Drafting Table	With proper lighting	15
Stool		15
Computer	Microsoft Windows XP SP2 Operating System Intel® Pentium® 4 Processor or AMD Athlon®, 2.2 GHz or Greater Intel AMD Dual Core Processor, 1.6 GHz or Greater 1 GB RAM 750 MB free Hard Disc space for Installation Microsoft Internet Explorer 6.0 (SPI or Higher)	5
Monitor	15 or 17 inches (1024 x 768 VGA with true colour)	5
Software	AutoCAD 2009 or later version Chief Architect 10 or Later Version Revit 3D Home or 3D Architect SKETCHUP	1 copy
ISO Standard/BS 3888	Technical Drawing	1
ISO Standard/PP 7307	Graphical symbols for use in schools and colleges	1
ISO Standard/PP 7308	Engineering Drawing Practice for schools and colleges	1
ISO Standard TC-S9	Buildings and civil engineering works	1
ISO Standard ICS - 91	Construction Material and Building	1
CUBiC (code)	Caribbean Uniform Building Codes Electrical code Plumbing code Structural code Wind code Earthquake code	1
Local Code		1

Students are expected to provide the following:

- (i) drawing paper;
- (ii) tee square;
- (iii) set squares (30° and 45°);
- (iv) drafting set;
- (v) metric scale;

- (vi) eraser;
- (vii) pencils;
- (viii) masking tape
- (ix) external storage device (thumb drive).

Western Zone Office
8 April 2015

CARIBBEAN EXAMINATIONS COUNCIL

Caribbean Advanced Proficiency Examination®



BUILDING AND MECHANICAL ENGINEERING DRAWING

Specimen Papers and Mark Schemes/Keys

Specimen Papers:

- Unit 1, Paper 01 Option A (Engineering Drawing)
- Unit 1, Paper 01 Option B (Building Drawing)
- Unit 1, Paper 02 (Building and Mechanical Engineering Drawing)
- Unit 2, Paper 01 Option A (Mechanical Engineering Drawing and Design)
- Unit 2, Paper 01 Option B (Building Drawing and Design)
- Unit 2, Paper 02 Option A (Mechanical Engineering Drawing and Design)
- Unit 2, Paper 02 Option B (Building Drawing and Design)

Mark Schemes and Keys:

- Unit 1, Paper 01 Option A (Engineering Drawing)
- Unit 1, Paper 01 Option B (Building Drawing)
- Unit 1, Paper 02 (Building and Mechanical Engineering Drawing)
- Unit 2, Paper 01 Option A (Mechanical Engineering Drawing and Design)
- Unit 2, Paper 01 Option B (Building Drawing and Design)
- Unit 2, Paper 02 Option A (Mechanical Engineering Drawing and Design)
- Unit 2, Paper 02 Option B (Building Drawing and Design)



TEST CODE **02168010**

SPEC 2015/02168010

C A R I B B E A N E X A M I N A T I O N S C O U N C I L

CARIBBEAN ADVANCED PROFICIENCY EXAMINATION®

BUILDING AND MECHANICAL ENGINEERING DRAWING

OPTION A – ENGINEERING DRAWING

SPECIMEN PAPER

Unit 1 – Paper 01

1 hour 30 minutes

READ THE FOLLOWING INSTRUCTIONS CAREFULLY.

1. This test consists of 45 items. You will have 1 hour and 30 minutes to answer them.
2. Each item in this test has four suggested answers lettered (A), (B), (C), (D). Read each item you are about to answer and decide which choice is best.
3. Look at the sample item below.

Sample Item

In drawings, thin, short dashes represent

- (A) hidden details
- (B) adjacent parts
- (C) movable parts
- (D) irregular details

Sample Answer



The best answer to this item is “hidden details”, so (A) has been shaded.

4. If you want to change your answer, erase it completely before you fill in your new choice.
5. When you are told to begin, turn the page and work as quickly and as carefully as you can. If you cannot answer an item, go on to the next one. You may return to that item later.
6. You may do any rough work in this booklet.
7. Figures are not necessarily drawn to scale.

DO NOT TURN THIS PAGE UNTIL YOU ARE TOLD TO DO SO.

Copyright © 2015 Caribbean Examinations Council
All rights reserved.

1. Which of the following geometric shapes is obtained by cutting a right cone at an angle to its base?

- (A) Circle
- (B) Ellipse
- (C) Parabola
- (D) Hyperbola

2. Which of the following engineering curves may be defined as the locus of a point which moves away from another fixed point at uniform linear velocity and uniform angular velocity?

- (A) Involute
- (B) Cycloid
- (C) Epicycloid
- (D) Archimedean Spiral

Item 3 refers to the following diagram of a truncated cone.

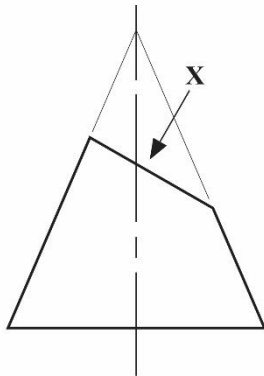

3. The view taken from the position of the arrow 'X' is an

- (A) oblique view
- (B) isometric view
- (C) auxillary view
- (D) orthographic view

Item 4 refers to the following diagram.

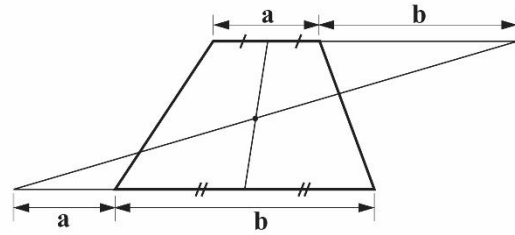

4. The diagram shows how to

- (A) find the area of a quadrilateral
- (B) determine the perimeter of a trapezium
- (C) find the centre of gravity of a trapezium
- (D) divide a trapezium into four parts of equal area

5. Which of the following curves is generated if a piece of string is wound around a cylinder?

- (A) Cycloid
- (B) Helix
- (C) Involute
- (D) Trochoid

6. Which of the following BEST describes the locus of a point which moves so that its distance from a focus bears a constant ratio of one to its perpendicular distance from the directrix?

- (A) Ellipse
- (B) Parabola
- (C) Hyperbola
- (D) Hypocycloid

7. The centroid coincides with the center of mass or the centre of gravity only if the material of the body is

- (A) solid
- (B) irregular
- (C) symmetrical
- (D) homogenous

8. If an area possesses two lines of symmetry, its centroid lies at
- (A) the end of each symmetry line
 - (B) their intersection of the symmetry
 - (C) 1/3 from point of intersection
 - (D) 1/2 from point of intersection
9. The first step in determining the centroid of a composite shape is
- (A) determining a first moment
 - (B) identifying common shapes
 - (C) identifying individual centroids for each shape
 - (D) calculating the complete area of the composite shape
10. A curve that is generated by a point that revolves uniformly around, up and down the surface of a cylinder is a
- (A) helix
 - (B) cycloid
 - (C) spring
 - (D) parabola

Item 11 refers to the following views of an oblique square pyramid.

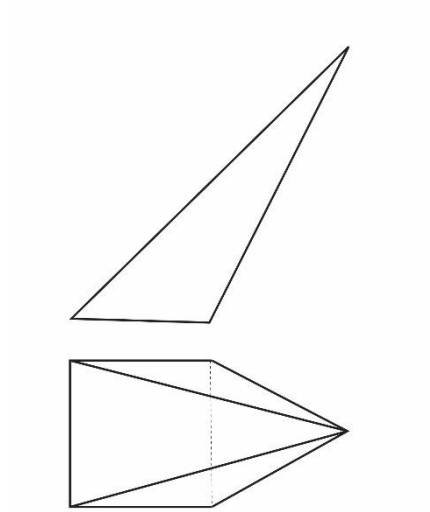

11. Which of the following is the MOST suitable method to use to construct the development of the oblique square pyramid?
- (A) Polar method
 - (B) Method of arcs
 - (C) Measuring sides
 - (D) Method of triangulation
12. In reference to orthographic projection, when a line passes through a plane, the point of intersection is
- (A) a trace
 - (B) first-angle projection
 - (C) third-angle projection
 - (D) oblique projection

Item 13 refers to the following types of lines used in drawings.

- I. Angular lines
- II. Perpendicular lines
- III. Curves

13. Which of the lines can be drawn using polar coordinates in CAD?

- (A) I and II only
- (B) I and III only
- (C) II and III only
- (D) I, II and III

14. Which of the following is NOT in the modify tool bar?

- (A) Erase
- (B) Array
- (C) Draw
- (D) Offset

15. Which of the following statements are TRUE of first angle projection?

- I. The base represents the horizontal plane on to which is projected the plan.
 - II. The three sides represent the three vertical planes on to which the front elevation and the two end elevations are projected.
 - III. The plan is in the vertical plane to the end elevation.
- (A) I and II only
 - (B) I and III only
 - (C) II and III only
 - (D) I, II and III

Item 16 refers to the following diagram.

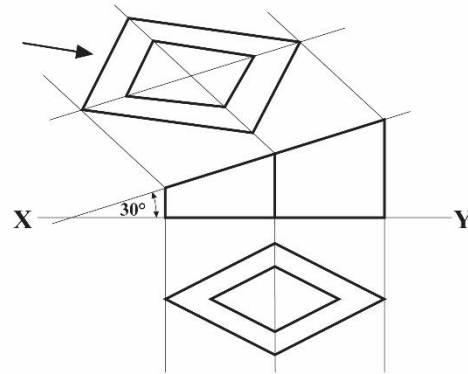

16. Which view is indicated by the arrow?

- (A) Plan view
- (B) Front view
- (C) Auxiliary plan
- (D) Sectional view

17. Which of the following describes a curve generated by a point on the circumference of a circle, which rolls without slipping along the outside of another circle?

- (A) Hypocycloid
- (B) Epicycloid
- (C) Cycloid
- (D) Trochoid

18. The primary reason for using an auxiliary view is to

- (A) locate centre marks
- (B) eliminate hidden lines
- (C) show cylinders as ellipses and spheres
- (D) create a true projection plane from an incline plane

19. Which of the following definitions BEST describes an ellipse?

- (A) Locus of a curve that moves around a cylindrical object
- (B) Locus of a point on the periphery of a circle which rolls on a straight path
- (C) Locus of a point moving such that the ratio of the distances from a fixed point and a fixed line remain constant
- (D) Locus of a point moving such that a curve is generated on the periphery of a circle which s along the foci

20. A bicycle tyre picks up a thumb tack as the cyclist rode an up curving ramp. Which of the following curves is produced if the locus of the tack is plotted?

- (A) Cycloid
- (B) Trochoid
- (C) Epicycloid
- (D) Hypocycloid

21. Which of the following curves is produced when the locus of a point on the periphery of a circle which rolls on a curved path is drawn?

- (A) Epicycloid
- (B) Trochoid
- (C) Cycloid
- (D) Involute

Item 22 refers to the following diagram of a figure drawn in isometric.



22. Which of the following orthographic views corresponds with the isometric figure?

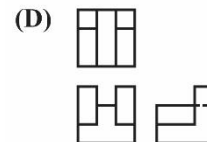
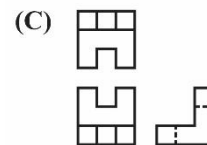
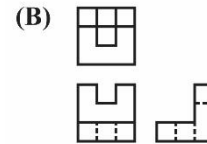
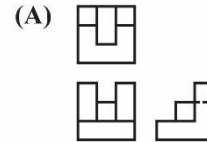

23. Which orthographic view is needed to produce an auxiliary elevation?

- (A) End
- (B) Plan
- (C) Section
- (D) Elevation

24. Which of the following pairs of drawings is necessary when drawing the development of a cylinder with an oblique top?

- (A) Plan and section
- (B) Plan and elevation
- (C) Elevation and section
- (D) Elevation and end elevation

25. A hexagonal pyramid that does NOT have its apex directly above the centre of its base is described as

- (A) a regular pyramid
- (B) a truncated pyramid
- (C) an oblique pyramid
- (D) a frustum pyramid

26. In isometric projection, the four center method is used to construct

- (A) an ellipse
- (B) a square
- (C) a triangle
- (D) a rectangle

27. Which of the following conditions must be met in order to classify a pictorial drawing as an isometric projection?

- (A) The isometric axes must be 30° apart
- (B) The isometric axes must be 45° apart
- (C) The isometric axes must be 60° apart
- (D) The isometric axis must be 120° apart

Items 28–29 refer to the following diagram.

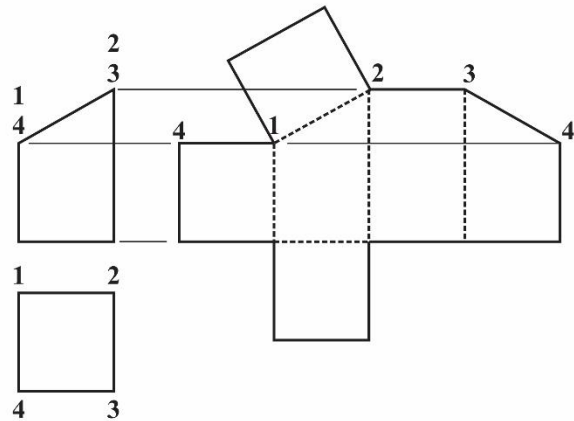

28. The development in the diagram shows a

- (A) square prism with square top
- (B) pyramid with rectangular top
- (C) square prism with an oblique top
- (D) hexagonal prism with a square top

29. What do the dotted lines in the development represent?

- (A) Width
- (B) Corners
- (C) Drawing line
- (D) Cutting line

Item 30 refers to the following pictorial diagram of a box.

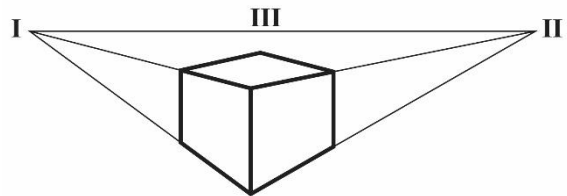

30. What type of projection was used to draw the box?

- (A) Oblique
- (B) Isometric
- (C) Perspective
- (D) Planometric

Item 31 refers to the following diagram.

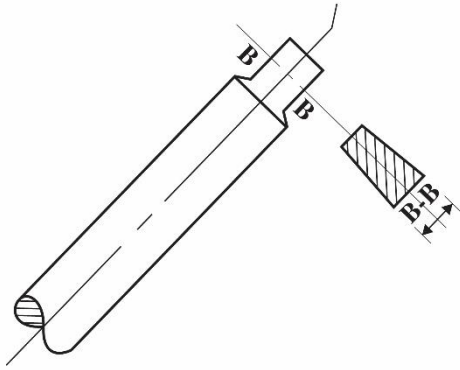

31. What type of sectioning is shown in the diagram?

- (A) Aligned section
- (B) Half section
- (C) Revolved section
- (D) Removed section

32. The distance that a follower moves in one revolution while in contact with the cam is called

- (A) fall
- (B) rise
- (C) dwell
- (D) displacement

33. Hatching lines are used for

- (A) identifying machine parts
- (B) displaying saw-tooth lines
- (C) showing cut-off sections
- (D) displaying internal components

34. The standard thickness of hatching lines is

- (A) 0.1 mm
- (B) 0.3 mm
- (C) 0.5 mm
- (D) 0.7 mm

35. Which of the following items is NOT sectioned?

- (A) Keys
- (B) Shafts
- (C) Pulleys
- (D) Nuts and bolts

Item 36 refers to the following balloon referencing (item listing) arrow terminations.

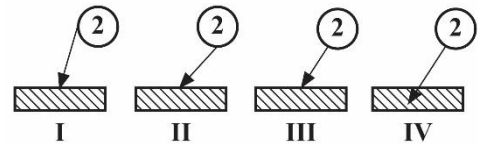

36. Which of the balloon references is correct?

- (A) I
- (B) II
- (C) III
- (D) IV

37. Which of the following is NOT part of an items (parts) listing?

- (A) MATL.
- (B) No. OFF
- (C) REMARKS
- (D) TOLERANCE

Items 38 – 40 refers to the following diagram of a performance curve for a cam profile.

38. What type of motion will be imparted to the follower during its rise?

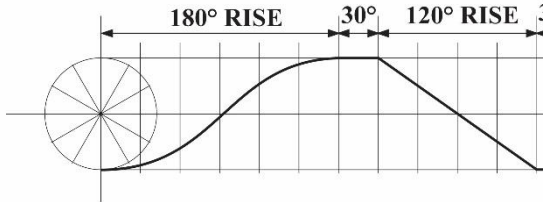

- (A) Dwell
- (B) Uniform velocity
- (C) Simple harmonic motion
- (D) Uniform acceleration and retardation

39. For what angle of rotation is the cam follower neither rising nor falling?

- (A) 30°
- (B) 60°
- (C) 90°
- (D) 120°

40. The cam will fall with

- (A) 120° uniform retardation
- (B) 150° uniform retardation
- (C) 120° uniform velocity
- (D) 150° uniform velocity

Items 41–43 refer to the following diagram showing dimension elements.

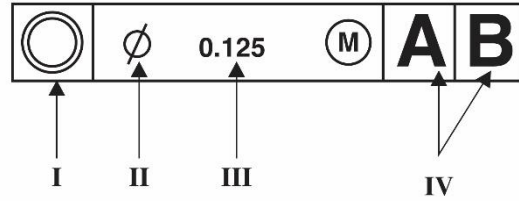

41. Which element is denoted by the arrow labelled 'III'?

- (A) Tolerance value
- (B) Geometric condition
- (C) Optional diameter
- (D) Material condition of tolerance

42. Which element is denoted by the arrow labelled 'IV'?

- (A) Datum
- (B) Optional diameter
- (C) Geometric condition
- (D) Tolerance value

43. Which element represents concentric circles?

- (A) I
- (B) II
- (C) III
- (D) IV

44. Which of the following is a disadvantage of the knife-edge follower?

- (A) It wears faster.
- (B) It slows down the cam.
- (C) It is difficult to construct.
- (D) It has the ability to move around the cam easily.

45. Which of the following valves is MOST suitable for allowing flow in one direction, uses pressure and velocity to flow, and cannot be controlled from an external source?

- (A) Globe
- (B) Gate
- (C) Ball
- (D) Check

END OF TEST



TEST CODE **02169010**

SPEC 2015/02169010

C A R I B B E A N E X A M I N A T I O N S C O U N C I L

CARIBBEAN ADVANCED PROFICIENCY EXAMINATION®

BUILDING AND MECHANICAL ENGINEERING DRAWING

OPTION B – BUILDING DRAWING

SPECIMEN PAPER

Unit 1 – Paper 01

1 hour 30 minutes

READ THE FOLLOWING INSTRUCTIONS CAREFULLY.

1. This test consists of 45 items. You will have 1 hour and 30 minutes to answer them.
2. Each item in this test has four suggested answers lettered (A), (B), (C), (D). Read each item you are about to answer and decide which choice is best.
3. Look at the sample item below.

Sample Item

In drawings, thin, short dashes represent

- (A) hidden details
- (B) adjacent parts
- (C) movable parts
- (D) irregular details

Sample Answer



The best answer to this item is “hidden details”, so A has been shaded.

4. If you want to change your answer, erase it completely before you fill in your new choice.
5. When you are told to begin, turn the page and work as quickly and as carefully as you can. If you cannot answer an item, go on to the next one. You may return to that item later.
6. You may do any rough work in this booklet.
7. Figures are not necessarily drawn to scale.

DO NOT TURN THIS PAGE UNTIL YOU ARE TOLD TO DO SO.

Copyright © 2015 Caribbean Examinations Council
All rights reserved.

1. Which of the following geometric shapes is obtained by cutting a right cone at an angle to its base?

- (A) Circle
- (B) Ellipse
- (C) Parabola
- (D) Hyperbola

2. Which of the following engineering curves may be defined as the locus of a point which moves away from another fixed point at uniform linear velocity and uniform angular velocity?

- (A) Involute
- (B) Cycloid
- (C) Epicycloid
- (D) Archimedean spiral

Item 3 refers to the following diagram of a truncated cone.

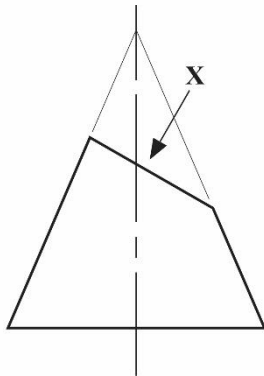

3. The view taken from the position of the arrow 'X' is an

- (A) oblique view
- (B) isometric view
- (C) auxillary view
- (D) orthographic view

Item 4 refers to the following diagram.

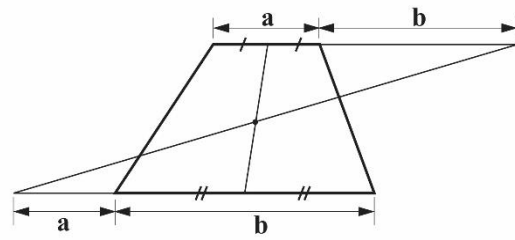

4. The diagram shows how to

- (A) find the area of a quadrilateral
- (B) determine the perimeter of a trapezium
- (C) find the centre of gravity of a trapezium
- (D) divide a trapezium into four parts of equal area

5. Which of the following curves is generated if a piece of string is wound around a cylinder?

- (A) Cycloid
- (B) Helix
- (C) Involute
- (D) Trochoid

6. Which of the following BEST describes the locus of a point which moves so that its distance from a focus bears a constant ratio of one to its perpendicular distance from the directrix?

- (A) Ellipse
- (B) Parabola
- (C) Hyperbola
- (D) Hypocycloid

7. The centroid coincides with the centre of mass or the centre of gravity only if the material of the body is

- (A) solid
- (B) irregular
- (C) symmetrical
- (D) homogenous

8. If an area possesses two lines of symmetry, its centroid lies at
- (A) the end of each symmetry line
 - (B) their intersection of the symmetry
 - (C) $1/3$ from point of intersection
 - (D) $1/2$ from point of intersection
9. The first step in determining the centroid of a composite shape is
- (A) determining a first moment
 - (B) identifying common shapes
 - (C) identifying individual centroids for each shape
 - (D) calculating the complete area of the composite shape
10. A curve that is generated by a point that revolves uniformly around, up and down the surface of a cylinder is a
- (A) helix
 - (B) cycloid
 - (C) spring
 - (D) parabola

Item 11 refers to the following views of an oblique square pyramid.

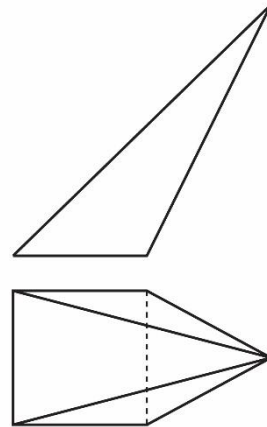

11. Which of the following is the MOST suitable method to use to construct the development of the oblique square pyramid?
- (A) Polar method
 - (B) Method of arcs
 - (C) Measuring sides
 - (D) Method of triangulation
12. In reference to orthographic projection, when a line passes through a plane, the point of intersection is
- (A) a trace
 - (B) first-angle projection
 - (C) third-angle projection
 - (D) oblique projection

Item 13 refers to the following types of lines used in drawings.

- I. Angular lines
- II. Perpendicular lines
- III. Curves

13. Which of the lines can be drawn using polar coordinates in CAD?

- (A) I and II only
- (B) I and III only
- (C) II and III only
- (D) I, II and III

14. Which of the following is NOT in the modify tool bar?

- (A) Erase
- (B) Array
- (C) Draw
- (D) Offset

15. Which of the following statements are TRUE of first angle projection?

- I. The base represents the horizontal plane on to which is projected the plan.
 - II. The three sides represent the three vertical planes on to which the front elevation and the two end elevations are projected.
 - III. The plan is in the vertical plane to the end elevation.
- (A) I and II only
 - (B) I and III only
 - (C) II and III only
 - (D) I, II and III

Item 16 refers to the following diagram.

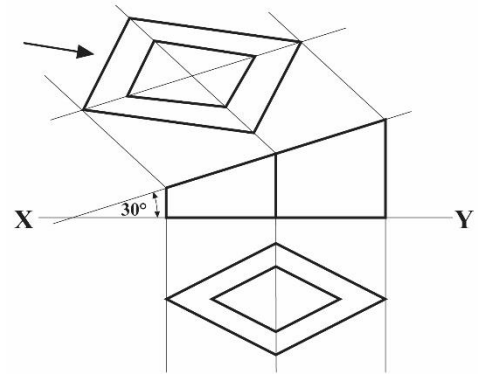

16. Which view is indicated by the arrow?

- (A) Plan view
- (B) Front view
- (C) Auxiliary plan
- (D) Sectional view

17. Which of the following describes a curve generated by a point on the circumference of a circle, which rolls without slipping along the outside of another circle?

- (A) Hypocycloid
- (B) Epicycloid
- (C) Cycloid
- (D) Trochoid

18. The primary reason for using an auxiliary view is to

- (A) locate centre marks
- (B) eliminate hidden lines
- (C) show cylinders as ellipses and spheres
- (D) create a true projection plane from an incline plane

19. Which of the following definitions BEST describes an ellipse?

- (A) Locus of a curve that moves around a cylindrical object
- (B) Locus of a point on the periphery of a circle which rolls on a straight path
- (C) Locus of a point moving such that the ratio of the distances from a fixed point and a fixed line remain constant
- (D) Locus of a point moving such that a curve is generated on the periphery of a circle which rolls along the foci

20. A bicycle tyre picks up a thumb tack as the cyclist rode an up curving ramp. Which of the following curves is produced if the locus of the tack is plotted?

- (A) Cycloid
- (B) Trochoid
- (C) Epicycloid
- (D) Hypocycloid

21. Which of the following curves is produced when the locus of a point on the periphery of a circle which rolls on a curved path is drawn?

- (A) Epicycloid
- (B) Trochoid
- (C) Cycloid
- (D) Involute

Item 22 refers to the following diagram of a figure drawn in isometric.



22. Which of the following orthographic views corresponds with the isometric figure?

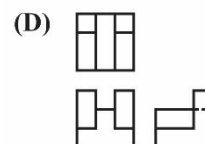
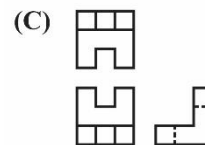
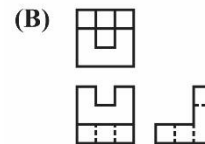
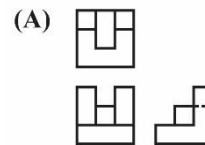

23. Which orthographic view is needed to produce an auxiliary elevation?

- (A) End
- (B) Plan
- (C) Section
- (D) Elevation

24. Which of the following pair of drawings is necessary when drawing the development of a cylinder with an oblique top?

- (A) Plan and section
- (B) Plan and elevation
- (C) Elevation and section
- (D) Elevation and end elevation

25. A hexagonal pyramid that does NOT have its apex directly above the centre of its base is described as

- (A) a regular pyramid
- (B) a truncated pyramid
- (C) an oblique pyramid
- (D) a frustum pyramid

26. In isometric projection, the four center method is used to construct

- (A) an ellipse
- (B) a square
- (C) a triangle
- (D) a rectangle

27. Which of the following conditions must be met in order to classify a pictorial drawing as an isometric projection?

- (A) The isometric axes must be 30° apart.
- (B) The isometric axes must be 45° apart.
- (C) The isometric axes must be 60° apart.
- (D) The isometric axis must be 120° apart.

Items 28–29 refer to the following diagram.

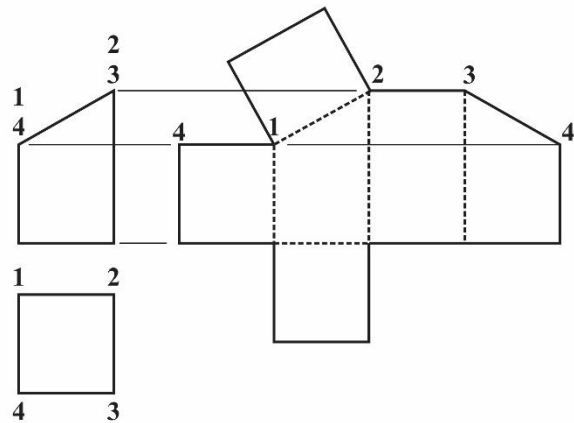

28. The development in the diagram shows a

- (A) square prism with square top
- (B) pyramid with rectangular top
- (C) square prism with an oblique top
- (D) hexagonal prism with a square top

29. What do the dotted lines in the development represent?

- (A) Width
- (B) Corners
- (C) Drawing line
- (D) Cutting line

Item 30 refers to the following pictorial diagram of a box.

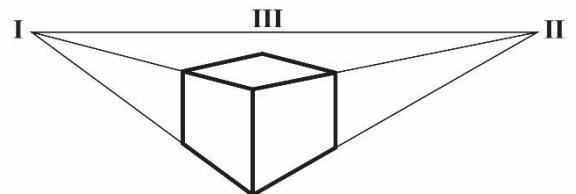

30. What type of projection was used to draw the box?

- (A) Oblique
- (B) Isometric
- (C) Perspective
- (D) Planometric

31. The unit of modulus of elasticity is the same as that of
- (A) stress, strain and pressure
 - (B) strain, pressure and force
 - (C) stress, force and modulus of rigidity
 - (D) stress, pressure and modulus of rigidity
32. Which of the following is NOT a component of building structures?
- (A) Roofs
 - (B) Beams
 - (C) Columns
 - (D) Rendering
33. The most commonly used type of foundation is the
- (A) pile
 - (B) strip
 - (C) pad
 - (D) step
34. If each common rafter (including tail) of a gable roof is 14' long, how many 16' pieces of lumber constructed 24" on centres, will be needed to provide common rafters for a 30' long building with no overhang?
- (A) 28
 - (B) 30
 - (C) 32
 - (D) 42
35. Which of the following identifies the horizontal timber piece at the apex of a roof truss that supports the common rafters?
- (A) Ridge board
 - (B) Hip rafter
 - (C) Eave board
 - (D) Valley rafter
36. Which of the following in architectural drawing is used to illustrate detail structural components?
- (A) Pictorial drawings
 - (B) Perspective drawings
 - (C) Sectional drawings
 - (D) Oblique drawings
37. What is the MOST appropriate way of improving the bearing capacity of a water logged soil?
- (A) Compacting the soil
 - (B) Draining the soil
 - (C) Increasing the soil depth
 - (D) Adding more soil
38. An overview of boundaries, proposed buildings, natural features and entrance is shown on a
- (A) site plan
 - (B) floor plan
 - (C) pictorial drawing
 - (D) front elevation
39. If a sewer line is blocked, which of the following would give clear access for checking?
- (A) Manhole
 - (B) Septic tank
 - (C) Soakaway
 - (D) Main drain

Items 40–41 refer to the following diagram with several components labelled.

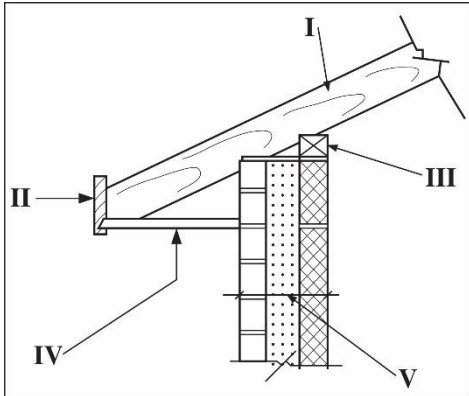

40. The diagram shows

- (A) a roof plan
- (B) eaves detail
- (C) roof detail
- (D) column detail

41. The component labelled II indicates the

- (A) eave
- (B) rafter
- (C) wall plate
- (D) fascia board

42. Which of the following is not a function of a foundation?

- (A) Aesthetics
- (B) Load distribution
- (C) Anchoring the building
- (D) Transferring loads to the subsoil

43. The main purpose of a legend on an electrical plan is to

- (A) locate the site
- (B) locate pot head
- (C) explain fixtures
- (D) explain contours

44. A stair which extends from one level to another without turns or winders may be classified as a

- (A) straight run
- (B) quarter turn
- (C) half turn
- (D) spiral

45. A quarter turn stairway will make a turn of

- (A) 45°
- (B) 60°
- (C) 90°
- (D) 180°

END OF TEST

C A R I B B E A N E X A M I N A T I O N S C O U N C I L

C A R I B B E A N A D V A N C E D P R O F I C I E N C Y E X A M I N A T I O N[®]

B U I L D I N G A N D M E C H A N I C A L E N G I N E E R I N G D R A W I N G

Unit 1 – Paper 02

2 hours 30 minutes

SPECIMEN PAPER

GENERAL INFORMATION

1. **This paper consists of EIGHT questions.**
2. **Answer ALL questions from Sections A and B and ALL questions from either Section C or D.**
3. **EACH question is worth 20 marks. You are advised to spend approximately 25 minutes on each question.**
4. **Silent, non-programmable calculators may be used for this examination.**
5. **For this examination, each candidate should have:**
 - Two sheets of drawing paper (both sides may be used)**
 - Two sheets of graph paper**
 - Drawing board and T-square**
 - Two sheets of tracing paper**
 - Drawing instruments**
 - Data sheet B.S.4500 (both hole and shaft basis), provided as an insert**

INSTRUCTIONS TO CANDIDATES

1. **All dimensions given are in millimetres unless otherwise stated.**
2. **Where scales are not stated the full size should be applied.**
3. **All geometrical construction lines MUST be visible on all drawings.**
4. **When first-angle or third-angle is not specified, the choice of projection is left to the candidate's discretion, in which case the type of projection used MUST be clearly stated.**
5. **The candidate should use his/her own judgement to supply any dimensions or other details not directly shown on the drawings.**
6. **The number of EACH question MUST be written next to the solution.**
7. **Each candidate MUST enter his/her school code and registration number in the appropriate space at the bottom of the drawing paper.**

SECTION A
MODULE 1
GEOMETRY 1

Answer ALL questions from this section.

1. Figure 1 shows the framework for a parabola.

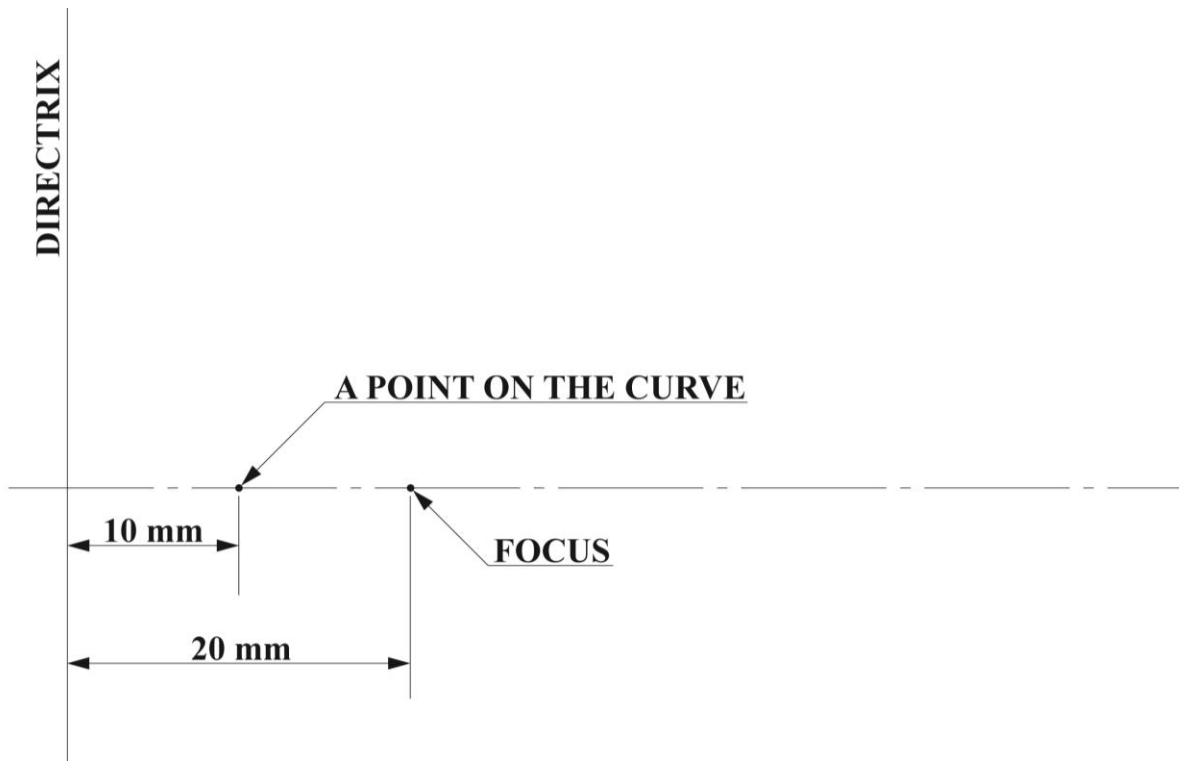

Figure 1. Framework for parabola

- (a) Draw a parabola given the relative positions of the focus and the directrix as shown in Figure 1. **[5 marks]**
- (b) (i) Draw an Archimedean spiral of one convolution with the shortest and longest radii of lengths 10 mm and 50 mm respectively.
- (ii) Draw the normal and tangent at a point on the curve, 25 mm from the pole. **[11 marks]**
- (c) Sketch an ellipse showing the following features. Label these features.
- Vertices
 - Foci
 - Directrix
 - Axes
- [4 marks]**

Total 20 marks

2. Figure 2 shows a plate cam with its camshaft clearly identified.

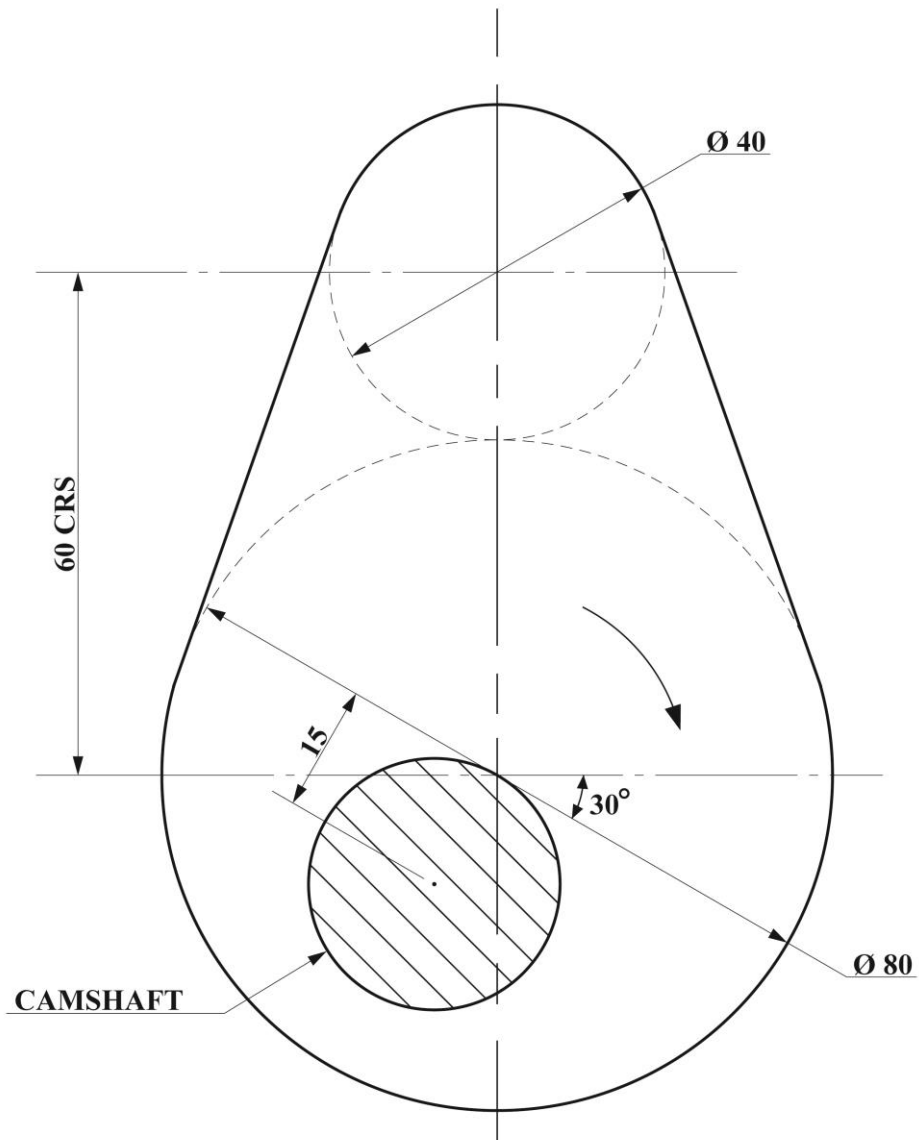

Figure 2. Plate cam

- (a) Reproduce the cam shown in Figure 2. **[4 marks]**
- (b) Project the complete performance diagram for a knife edge follower. **[9 marks]**
- (c) Fully label the drawing. **[2 marks]**
- (d) Identify the dwell period on your performance diagram. **[3 marks]**
- (e) Explain why the performance curve is NOT symmetrical. **[2 marks]**

Total 20 marks

SECTION B

MODULE 2

GEOMETRY 2

Answer ALL questions from this section.

3. Construct two turns of a right hand, single start square thread of 75 mm outside diameter and 25 mm lead. Do NOT show hidden details. **Total 20 marks**
4. Figure 4 shows a cylinder intersecting a right cone at an angle of 60° to the horizontal.

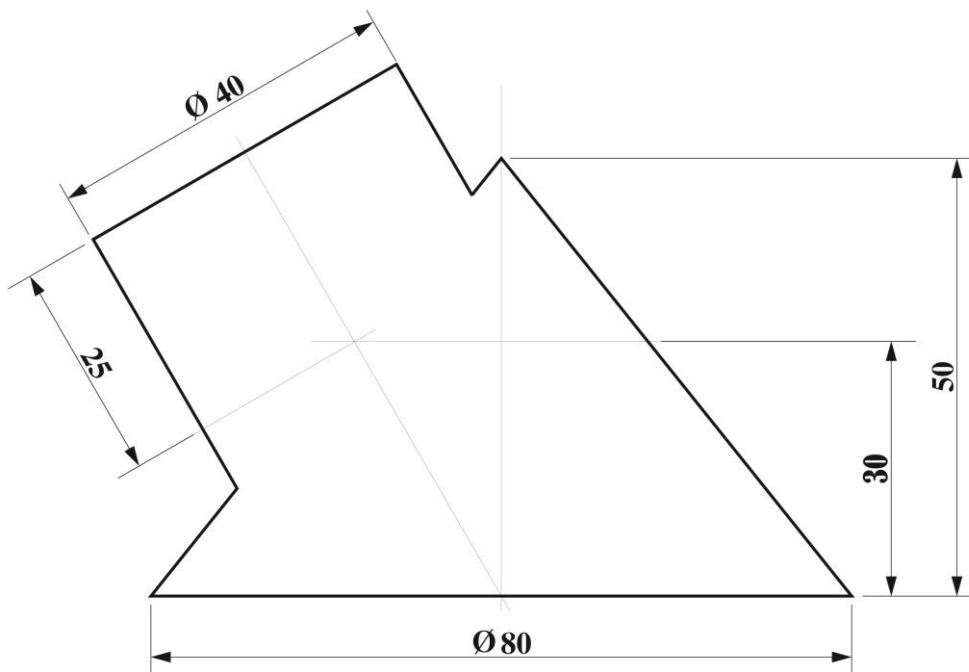

Figure 3. Cylinder intersecting right cone

Draw the plan and elevation. Project the end of the inclined cylinder to the horizontal plane to obtain the ellipse (auxiliary plan). Hence, draw the curve of interpenetration in both elevation and plan.

Total 20 marks

SECTION C
MODULE 3A
ENGINEERING DRAWING

Answer ALL questions from this section.

- 5.** A draftsman is given a rigid stool to use and finds that he is uncomfortable because he is unable to swivel the stool.
- (a) Define the design problem.
 - (b) Suggest THREE possible solutions (using freehand sketches).
 - (c) Give details of ONE possible solution and explain its special features.
 - (d) Select a material for the construction of your design and evaluate your choice of material.

Total 20 marks

- 6.** Figures 4 and 5 show drawings of an assembled centrifugal pump and motor.

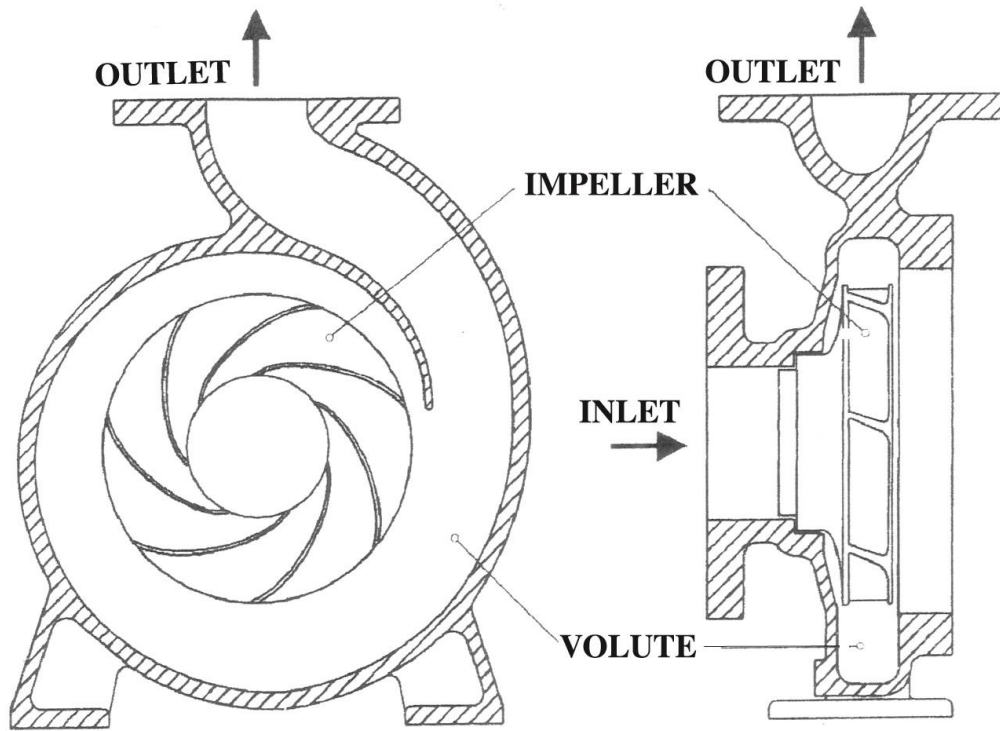

Figure 4. Centrifugal pump

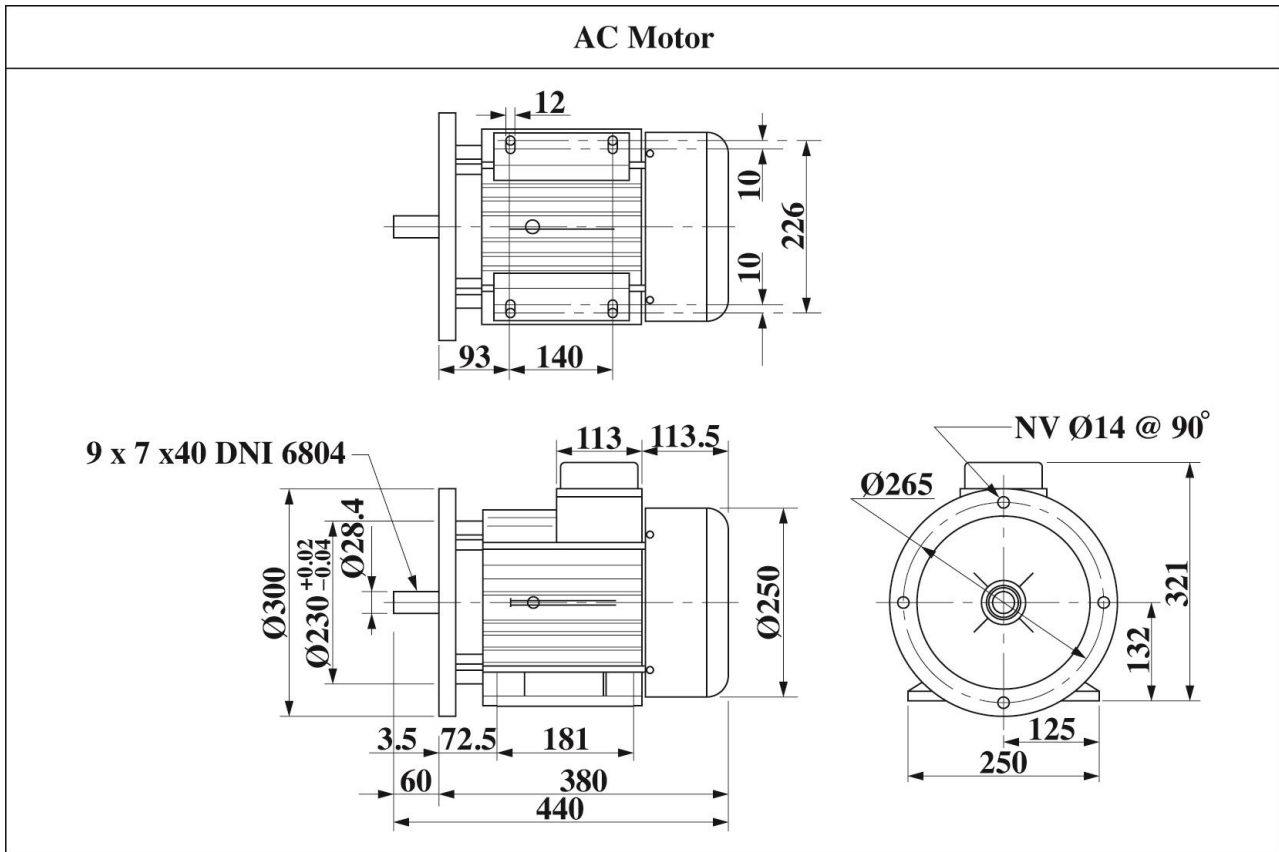

Figure 5. AC motor

- (a) Sketch freehand and in good proportion a cutaway view of the pump and motor, and show how they are directly coupled. (**Show the external components of the pump.**)
- (b) Label the components of the assembly.
- (c) Give an application of a centrifugal pump.

Total 20 marks

SECTION D

MODULE 3B

BUILDING DRAWING

Answer ALL questions from this section.

7. Figure 6 on the attached sheet outlines sketches of a plan and elevation for a straight flight timber staircase from the upper floor of a suspended wooden decking floor to the concrete ground floor of the main building. The decking spans the width of the building and the staircase is located in the centre of the span as shown in the outline. In addition, the finished decking floor is 2.4750 m above the finished concrete ground floor. And continued using teak lumber.

Using the specification below draw the following:

- (a) Longitudinal section through A.A of the staircase from the top of the decking to ground floor. Scale 1:10. **(16 marks)**
- (b) A removed section showing a construction joint used at the treads and risers. Scale approximately 1:5. **(4 marks)**

Specifications:

Newel post — 100 mm × 100 mm

Staircase width — 900 mm

Threaders — 38 mm × 275 mm

Risers — 38 mm × 175 mm

Trimmer joint — 50 mm × 150 mm

Outer String — 25 mm × 300 mm

Tongue & groove Flooring Board — 21 mm × 150 mm

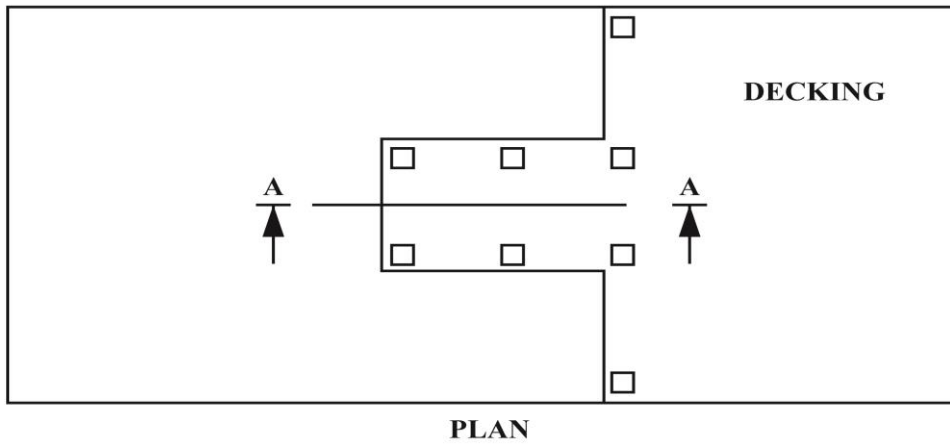
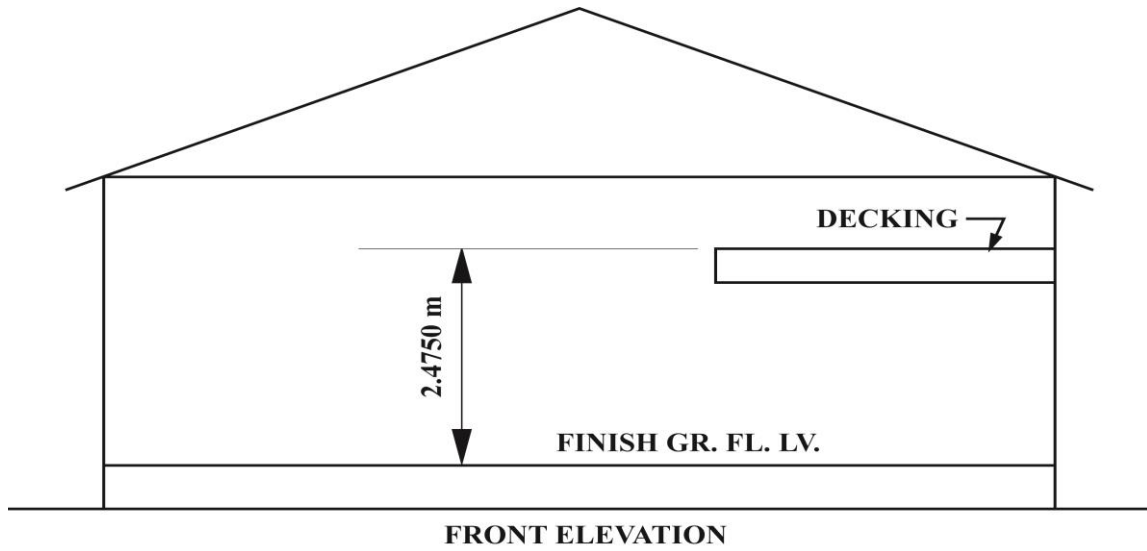

Figure 1. Outlined plan and elevation

Total 20 marks

8. Figure 7 shows the upper floor plan of a beach house and a main sewer line.

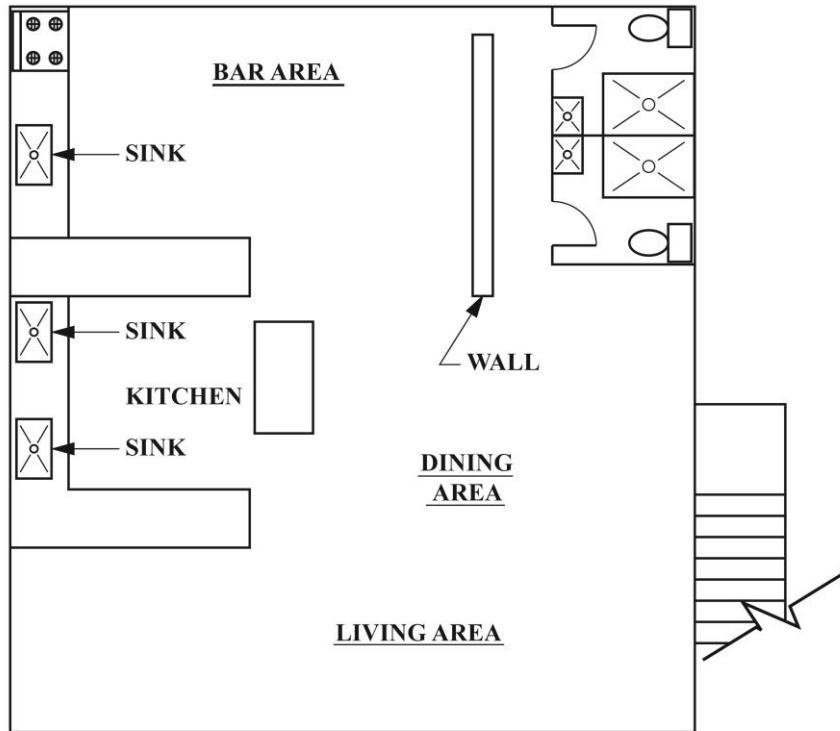

Figure 7. Upper floor plan

Redraw the layout of the beach house in proportion to the given figure showing

- (a) the existing plumbing fixtures and main sewer line
- (b) the flow of the waste water and solids from the fixtures to the main sewer line. Label all necessary structures and fittings as required by building codes locally to assist with the flow for the sewer system.

END OF TEST

IF YOU FINISH BEFORE TIME IS CALLED, CHECK YOUR WORK ON THIS TEST.



TEST CODE **02268010**

SPEC 2015/02268010

C A R I B B E A N E X A M I N A T I O N S C O U N C I L

CARIBBEAN ADVANCED PROFICIENCY EXAMINATION®

BUILDING AND MECHANICAL ENGINEERING DRAWING

OPTION A – MECHANICAL ENGINEERING DRAWING AND DESIGN

SPECIMEN PAPER

Unit 2 – Paper 01

1 hour 30 minutes

READ THE FOLLOWING INSTRUCTIONS CAREFULLY.

1. This test consists of 45 items. You will have 1 hour and 30 minutes to answer them.
2. Each item in this test has four suggested answers lettered (A), (B), (C), (D). Read each item you are about to answer and decide which choice is best.
3. Look at the sample item below.

Sample Item

In drawings, thin, short dashes represent

- (A) hidden details
- (B) adjacent parts
- (C) movable parts
- (D) irregular details

Sample Answer



The best answer to this item is “hidden details”, so A has been shaded.

4. If you want to change your answer, erase it completely before you fill in your new choice.
5. When you are told to begin, turn the page and work as quickly and as carefully as you can. If you cannot answer an item, go on to the next one. You may return to that item later.
6. You may do any rough work in this booklet.
7. Figures are not necessarily drawn to scale.

DO NOT TURN THIS PAGE UNTIL YOU ARE TOLD TO DO SO.

Copyright © 2015 Caribbean Examinations Council
All rights reserved.

1. Which of the following is the CORRECT formula for calculating the circular pitch (C.P.) for an involute spur gear?

(A) $C.P. = \frac{PCD \times \pi}{T}$

(B) $C.P. = \frac{T \times \pi}{PCD}$

(C) $C.P. = \frac{m \times \pi}{PCD}$

(D) $C.P. = \frac{PCD}{T \times M}$

2. What is the pitch circle diameter of an involute spur gear, given that the metric module (m) = 10 and the number of teeth (T) = 25?

(A) 50 mm

(B) 125 mm

(C) 250 mm

(D) 350 mm

3. Which of the following mechanisms is used on a typical drill press machine to transmit power from the electric motor to the spindle?

(A) Gear system

(B) Lever system

(C) Chain drive system

(D) Pulley belt drive system

Items 4–6 refer to the following diagram showing a component of a lathe with several parts labelled.

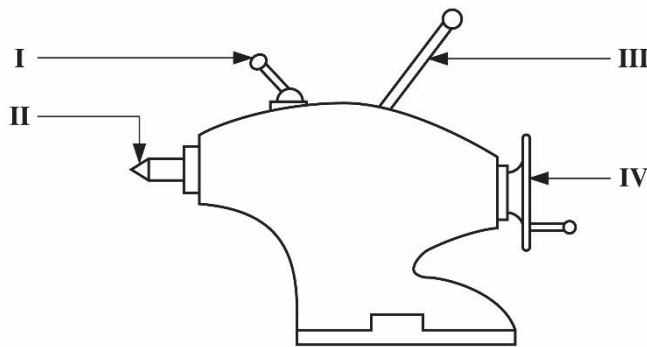

4. What is the name of the component illustrated in the diagram?
- (A) Headstock
 - (B) Tailstock
 - (C) Toolpost
 - (D) Compound Slide
5. Which of the labelled features is used for supporting a work piece between centres?
- (A) I
 - (B) II
 - (C) III
 - (D) IV
6. Which of the labelled features is responsible for the advancing and retracting of the sleeve?
- (A) I
 - (B) II
 - (C) III
 - (D) IV

Items 7–8 refer to the following properties of materials.

- I Toughness
- II Ductility
- III Malleability
- IV Hardness

7. Which property gives a material the ability to resist scratches?
- (A) I
 - (B) II
 - (C) III
 - (D) IV

8. Which property is essential for materials that are to be used to make wires?
- (A) I
 - (B) II
 - (C) III
 - (D) IV
9. Which method of casting would be most efficient in the mass production of plastic soup bowls?
- (A) Net casting
 - (B) Die casting
 - (C) Sand casting
 - (D) Investment casting

Items 10–12 refer to the following line diagram of an arc welding setup with components labelled.

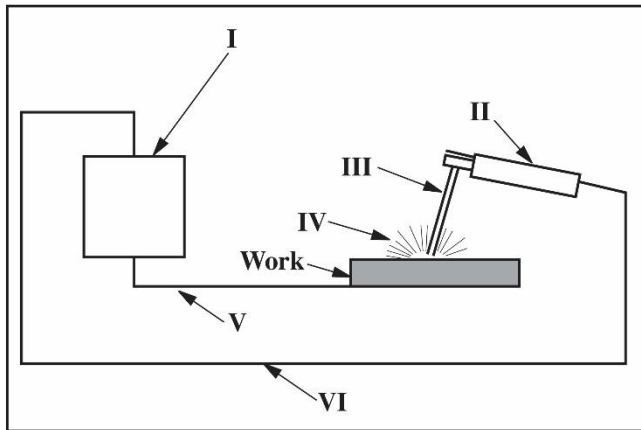

10. Which of the labelled arrows denotes the electrode holder?
- (A) I
 - (B) II
 - (C) III
 - (D) IV
11. Which feature of the setup does arrow VI represent?
- (A) Arc wire
 - (B) Electrode arc
 - (C) Electrode cable
 - (D) Worktable cable

12. Which of the labelled arrows identifies the electrode?

- (A) I
- (B) II
- (C) III
- (D) IV

Item 13 refers to the following diagram.

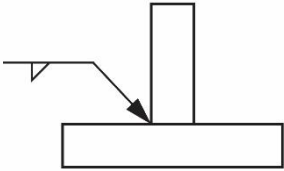

13. What information is being communicated by the welding symbol on the diagram?

- (A) Fillet weld, arrow side
- (B) Fillet weld, other side
- (C) Groove weld, both sides
- (D) Groove weld, underside

Items 14–15 refer to the following diagram which shows a typical drill bushing.

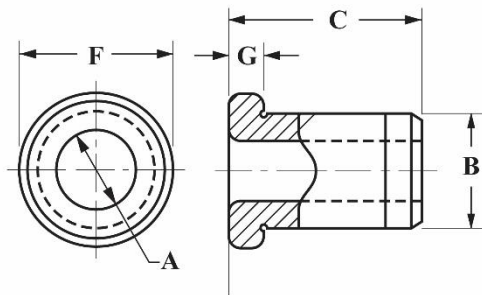

14. Which of the following is the BEST fit to use for the outside dimension of the bush?

- (A) H9/e9
- (B) H7/h6
- (C) H7/k6
- (D) H7/p6

15. Which of the following is the BEST fit for the inside dimension of the bush?

- (A) H9/e9
- (B) H7/h6
- (C) H7/k6
- (D) H7/p6

16. Which of the following is NOT a stage of the design process?

- (A) Synthesis
- (B) Evaluation
- (C) Presentation
- (D) Coordination

17. In the design process, recognition of need means

- (A) having persons in need of help
- (B) realizing that a design is complete
- (C) establishing that a component is to be designed
- (D) recognizing that needy people always have to be fed

18. In the design process, optimization is

- (A) ensuring all the design parts fit
- (B) testing a design for best results
- (C) revealing all the features of the design
- (D) creating all the ideas needed to complete the design

Items **19–21** refer to the following diagram which shows an orthographic view of a skew line.

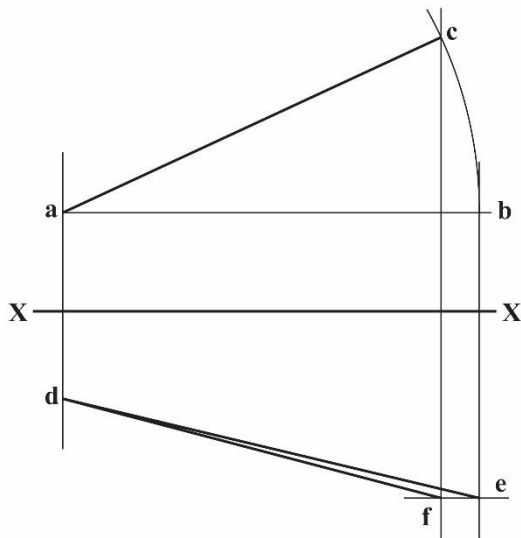

19. Which of these lines are projections of the original line in space?

- (A) a–c, d–f
- (B) a–b, d–e
- (C) a–c, a–b
- (D) d–f, d–e

20. Which line is the true length?

- (A) a–b
- (B) a–c
- (C) d–e
- (D) d–f

21. In which plane is figure abc located?

- (A) Vertical
- (B) Auxiliary
- (C) Horizontal
- (D) True length

Item 22 refers to the following diagram of a plastic chair.



22. Which of the following is the BEST manufacturing process for mass producing the chair?
- (A) Welding
 - (B) Fabrication
 - (C) Sand casting
 - (D) Injection moulding
23. Which of the following nonmetallic materials is capable of being formed or molded with the aid of heat, pressure, chemical reactions, or a combination of these?
- (A) Glass
 - (B) Metal
 - (C) Plastic
 - (D) Rubber
24. Which of the following types of plastic can be reheated, reformed or reused?
- (A) Silicone
 - (B) Bakelite
 - (C) Thermoplastic
 - (D) Thermosetting plastic
25. A conveyer belt to transport bags in the airport customs area is to be installed. What type of bearings would be MOST suitable to operate the conveyer belt?
- (A) Ball
 - (B) Roller
 - (C) Thrust
 - (D) Tapered

26. A continuous, flexible device that transmits motion from one wheel or pulley to another is a

- (A) gear
- (B) belt drive
- (C) chain drive
- (D) rack and pinion

Item 27 refers to the following diagram of a system of forces.

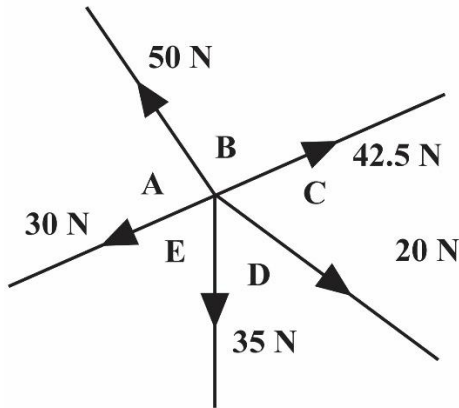

27. From a visual inspection of the diagram, which of the following statements is TRUE?

- (A) The system is in equilibrium.
- (B) The resultant of the system is 177.5 N.
- (C) Force 'AB' has no vertical component.
- (D) Force 'ED' has no horizontal component.

Items 28–29 refer to the following diagram of forces acting on a beam.

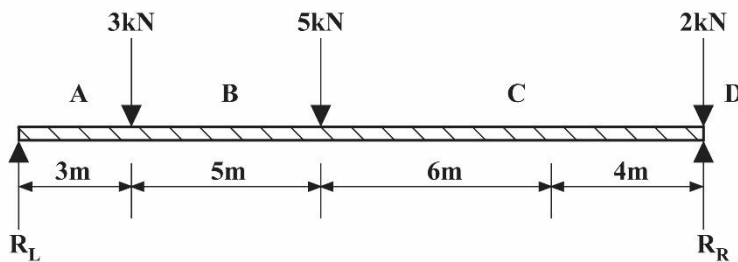

28. Which of the following is the resultant of R_L ?

- (A) 3.93 kN
- (B) 6.07 kN
- (C) 7.0 kN
- (D) 8.0 kN

29. Which of the following is the resultant of R_R ?

- (A) 3.93 kN
- (B) 6.07 kN
- (C) 7.0 kN
- (D) 8.0 kN

30. Which of the following gears is MOST suitable for transmitting power between two shafts that are at right angles to each other?

- (A) Spur
- (B) Bevel
- (C) Worm
- (D) Rack and pinion

31. Lubricants are used in bearings to

- I. Reduce friction between rubbing surfaces
- II. Act as coolant to carry off heat
- III. Reduce leakage

- (A) I and II only
- (B) I and III only
- (C) II and III only
- (D) I, II and III

32. In using the design concept, what term is used to describe the functional aspect of the design?

- (A) Ergonomics
- (B) Aesthetics
- (C) Economics
- (D) Anthropometrics

33. In using the design concept, what term is used to describe the appearance/beautification of the design?

- (A) Ergonomics
- (B) Aesthetics
- (C) Economics
- (D) Anthropometrics

- 34.** In the design concept, prototyping is used by the designer to
- I. see the product in three dimensions
 - II. sell the product to clients
 - III. check the engineering concept
- (A) I and II only
 - (B) I and III only
 - (C) II and III only
 - (D) I, II and III
- 35.** Which of the following is used to reduce the friction between an axle and a wheel and increase the efficiency of the turning force?
- (A) Bushings
 - (B) O-rings
 - (C) Bearings
 - (D) Sprockets
- 36.** Which of the following couplings provides an angular misalignment of up to 45°?
- (A) Split
 - (B) Friction
 - (C) Flange
 - (D) Universal joints
- 37.** Which of the following is used in a front wheel drive motor vehicle to transmit power from the transmission to the wheels, allowing angular misalignment between the driving shaft and the wheel?
- (A) Flanged coupling
 - (B) Universal joint
 - (C) Friction coupling
 - (D) Constant velocity joint

Items **38–40** refer to the following diagram which shows part of an involute spur gear.

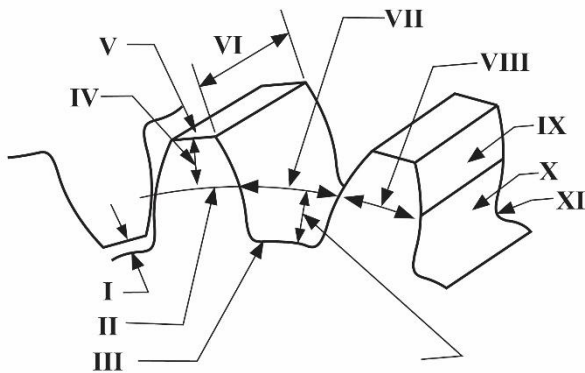

38. Which label identifies the dedendum?

- (A) II
- (B) III
- (C) IV
- (D) XII

39. Which label identifies the addendum?

- (A) II
- (B) III
- (C) IV
- (D) XII

40. Which of the following does the label I identify?

- (A) Flank
- (B) Clearance
- (C) Space width
- (D) Pitch circle

41. Which of the following angles are commonly used as the pressure angle when drawing a spur gear?

- I. 14.5°
- II. 20°
- III. 30°

- (A) I and II only
- (B) I and III only
- (C) II and III only
- (D) I, II and III

42. Which force member refers to a single truss segment that is neither in tension nor compression?

- (A) Concurrent
- (B) Coplanar
- (C) True
- (D) Zero

43. Which of the following formulas is used to determine the maximum bending moment for a simply supported, uniformly distributed load?

- (A) $wl^2/8$
- (B) $wl/4$
- (C) $wl^2/2$
- (D) wl^2

Items ~~44-45~~ refer to the following diagram which shows a set of keys.

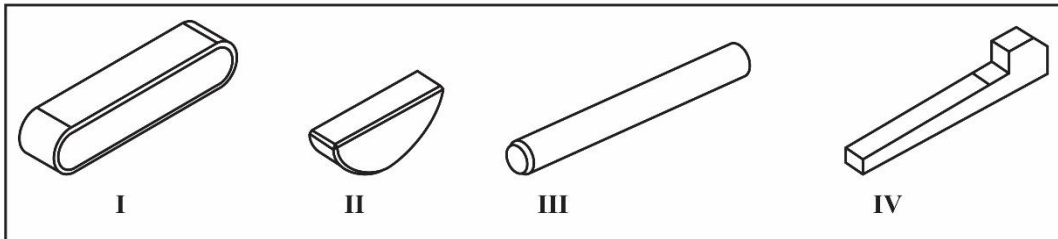

44. Which of the keys is a feather key?

- (A) I
- (B) II
- (C) III
- (D) IV

45. Which of the following identifies the dowel?

- (A) I
- (B) II
- (C) III
- (D) IV

END OF TEST



TEST CODE **02269010**

SPEC 2015/02269010

C A R I B B E A N E X A M I N A T I O N S C O U N C I L

CARIBBEAN ADVANCED PROFICIENCY EXAMINATION®

BUILDING AND MECHANICAL ENGINEERING DRAWING

OPTION B – BUILDING DRAWING AND DESIGN

SPECIMEN PAPER

Unit 2 – Paper 01

1 hour 30 minutes

READ THE FOLLOWING INSTRUCTIONS CAREFULLY.

1. This test consists of 45 items. You will have 1 hour and 30 minutes to answer them.
2. Each item in this test has four suggested answers lettered (A), (B), (C), (D). Read each item you are about to answer and decide which choice is best.
3. Look at the sample item below.

Sample Item

In drawings, thin, short dashes represent

- (A) hidden details
- (B) adjacent parts
- (C) movable parts
- (D) irregular details

Sample Answer



The best answer to this item is “hidden details”, so A has been shaded.

4. If you want to change your answer, erase it completely before you fill in your new choice.
5. When you are told to begin, turn the page and work as quickly and as carefully as you can. If you cannot answer an item, go on to the next one. You may return to that item later.
6. You may do any rough work in this booklet.
7. Figures are not necessarily drawn to scale.

DO NOT TURN THIS PAGE UNTIL YOU ARE TOLD TO DO SO.

Copyright © 2015 Caribbean Examinations Council
All rights reserved.

1. Ramming a stiff dry cement mortar mix into the space between new underpinning work and an existing structure is known as
 - (A) Pynford pinning
 - (B) final pinning
 - (C) pretest pinning
 - (D) wall underpinning
2. The method of underpinning that uses pairs of jacks or bored piles in conjunction with a reinforced beam is
 - (A) the Pynford stooling method
 - (B) wall underpinning
 - (C) traditional underpinning
 - (D) needle and piles
3. A load of wet concrete is considered to be approximately
 - (A) 1,400 Kg/m³
 - (B) 2,400 Kg/m³
 - (C) 3,400 Kg/m³
 - (D) 4,400 Kg/m³

Item 4 refers to the following diagram of a system of forces.

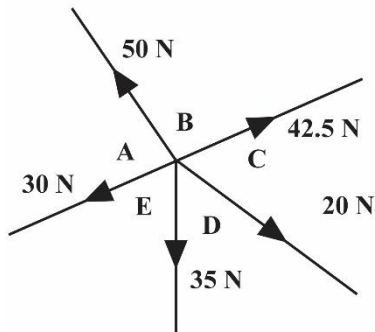

4. From a visual inspection of the diagram, which of the following statements is TRUE?
 - (A) The system is in equilibrium.
 - (B) The resultant of the system is 177.5 N.
 - (C) Force 'AB' has no vertical component.
 - (D) Force 'ED' has no horizontal component.
5. A concrete column 400 mm × 400 mm in cross sectional area is subjected to an axial thrust of 800 kN. What is the stress in the concrete?
 - (A) 2 N/mm²
 - (B) 5 N/mm²
 - (C) 8 N/mm²
 - (D) 10 N/mm²

6. Which one of the following statements BEST defines a project estimate?
- (A) An approximation of project time and cost targets, refined throughout the project life cycle.
 - (B) A prediction of a future condition or event based on information or knowledge available now.
 - (C) The value of useful work done at any given point in a project to give a measure of progress.
 - (D) A situation that affects or influences the outcome of the project expressed in time or cost terms.
7. The accuracy of a project estimate should
- (A) stay constant throughout the project life cycle
 - (B) decrease as a project progresses through its life cycle
 - (C) increase as a project progresses through its life cycle
 - (D) vary independently of where the project is in its life cycle
8. A key aspect of managing a project involves
- (A) identifying routine tasks
 - (B) planning to achieve defined objectives
 - (C) ensuring ongoing operations are maintained
 - (D) defining which operational systems to put in place
9. Project scheduling can BEST be defined as the process used to determine
- (A) overall project duration
 - (B) project cost estimating
 - (C) the project management plan
 - (D) the subcontractor's responsibilities
10. During project planning, execution involves taking actions to
- (A) establish a good plan
 - (B) close out the project
 - (C) provide feedback to key vendors
 - (D) ensure that activities in the project plan are completed
11. Which of the following statements is TRUE about couples?
- (A) Consist of two unequal forces acting in line with each other.
 - (B) The moment of a couple is $2 \times \text{force} \times \text{perpendicular distance between the forces}$.
 - (C) Consist of two equal unlike parallel forces acting out of line.
 - (D) Couples can be balanced by a single force of the same moment as the couple.

12. Which force member can carry loads in the event that variations are introduced in the normal external loading configuration?
- (A) Concurrent
 - (B) Coplanar
 - (C) True
 - (D) Zero
13. Which of the following formulae is used to determine the maximum bending moment for a simply supported, uniformly distributed load?
- (A) $wl^2/8$
 - (B) $wl/4$
 - (C) $wl^2/2$
 - (D) wl^2
14. Which of the following is the final stage in the designing process?
- (A) Synthesis
 - (B) Evaluation
 - (C) Presentation
 - (D) Analysis and optimization
15. Which of the following illustrates the correct sequence for distributing electrical power in a domestic dwelling?
- (A) Fuse , switch, load
 - (B) Load, fuse, switch
 - (C) Fuse, load, switch
 - (D) Switch, load, fuse
16. The purpose of the preconstruction conference is to
- (A) negotiate cost and sign the contract
 - (B) assign work to equipment operators
 - (C) agree on the project's requirements
 - (D) look at the equipment to be used
17. Which of the following describes the time-dependent phenomenon in which concrete is held under sustained stress?
- (A) Creep
 - (B) Shrinkage
 - (C) Contraction
 - (D) Temperature expansion

18. Which of the following is the number of days concrete takes to reach its compressive strength?

- (A) 3
- (B) 7
- (C) 28
- (D) 32

19. The recommended slump for mass concrete is

- (A) 25 mm to 50 mm
- (B) 50 mm to 100 mm
- (C) 100 mm to 125 mm
- (D) 125 mm to 150 mm

20. Which of the following describe the design principles of a blueprint?

- I. Aesthetics
 - II. Accessibility
 - III. Cost efficiency
 - IV. Energy conservation
-
- (A) I and II only
 - (B) I and III only
 - (C) I, II and III only
 - (D) I, II, III and IV

21. The MOST important element affecting the strength of concrete is the

- (A) method of mixing
- (B) water-to-cement ratio
- (C) volume of the mixture
- (D) weather condition during curing

22. Which of the following is the MOST suitable to apply as a first coat to an external grill to seal the surface and protect it from damp air?

- (A) Priming paint
- (B) Finishing paint
- (C) Undercoating paint
- (D) Water-based paint

23. Which of the following ingredients of paint provides body, colour and durability?
- (A) Linseed oil
 - (B) Pigment
 - (C) Synthetic resin
 - (D) White lead
24. Which of the following types of cement has the BEST resistance to natural sulphates found in some subsoils?
- (A) OPC
 - (B) CPC
 - (C) RHPC
 - (D) SRPC
25. Thermal insulation is defined as the
- (A) measure of a material's ability to resist heat
 - (B) measure of a material's ability to transmit heat
 - (C) ability for the natural flow of heat to a higher temperature source
 - (D) barrier to the natural flow of heat from an area of high temperature to an area of low temperature
26. Which of the following concrete mixes gives the strongest reinforced concrete for a flight of steps?
- (A) 1:2:4
 - (B) 1:3:6
 - (C) 1:2:8
 - (D) 1:5:10
27. Which of the following tests is conducted on concrete when it is in a solid state?
- (A) Silt
 - (B) Creep
 - (C) Slump
 - (D) Compression
28. Which of the following is the correct order for the stages of project management?
- (A) Scoping , planning, launching, monitoring and closing
 - (B) Planning, scoping, launching, closing and monitoring
 - (C) Launching, planning, scoping, monitoring and closing
 - (D) Scoping, planning, monitoring, launching and closing

Items 29 – 30 refers to the following diagram of forces acting on a beam.

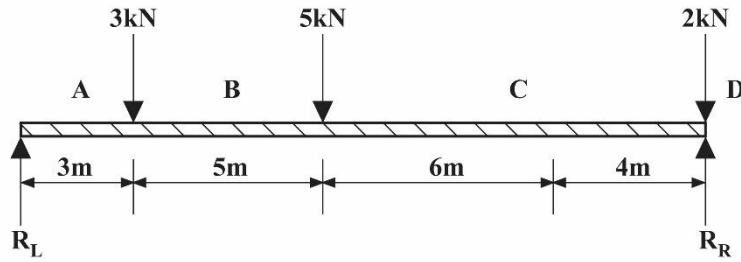

29. Which of the following is the resultant of R_L ?

- (A) 3.93 kN
- (B) 6.07 kN
- (C) 7.0 kN
- (D) 8.0 kN

30. Which of the following is the resultant of R_R ?

- (A) 3.93 kN
- (B) 6.07 kN
- (C) 7.0 kN
- (D) 8.0 kN

31. Which of the following is TRUE of thermoplastic?

- I. It can be reformed
- II. It cannot be reheated
- III. It can be reused

- (A) I and II only
- (B) I and III only
- (C) II and III only
- (D) I, II and III

32. If a 70 g sample of timber weighs 40 g after seasoning, what is the current moisture content of the sample?

- (A) 30 g
- (B) 110 g
- (C) 70%
- (D) 75%

33. Which of the following is NOT an appropriate internal wall finish?

- A. Tile
- B. Paint
- C. Cladding
- D. Concrete block

34. Which of the following is the term used to indicate the total rise of a staircase?

- (A) Lift
- (B) Going
- (C) Travel
- (D) Riser

35. In an effort to minimize twisting and general movement of joists, members are placed between them. Which of the following is NOT a method of placing members between joists?

- (A) In-line
- (B) Noggins
- (C) Staggered
- (D) Herringbone

36. An extended tread found between two consecutive flights of stairs is known as a

- (A) riser
- (B) landing
- (C) handrail
- (D) newel post

37. The MAIN disadvantage of a spiral staircase is that it has

- (A) tapered treads
- (B) a helical handrail
- (C) no landing
- (D) no strings

Item 38 refers to the following diagrams showing three forces acting at a point and a vector polygon resolving the forces.

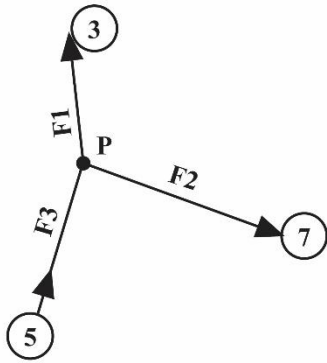

Three forces acting at a point

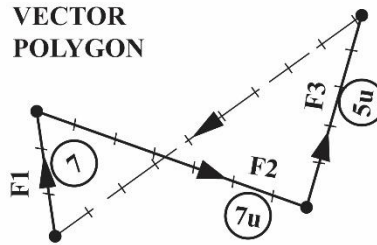

Vector Polygon

38. What is the magnitude of the force that will bring stability to the system of forces?

- (A) 7.3μ
- (B) 8.3μ
- (C) 9.3μ
- (D) 10.3μ

39. For which of the following is a hollow-core wood door BEST suited?

- (A) A residential exterior door
- (B) An interior residential door
- (C) A door in a private office
- (D) A twenty-minute smoke barrier door

40. A building's primary electric service system is usually sized on the basis of the

- (A) connected load
- (B) number of lights used
- (C) transformer rating
- (D) number of rooms to be lighted

41. An overview of boundaries, proposed buildings, natural features and entrance is shown on a

- (A) site plan
- (B) floor plan
- (C) pictorial drawing
- (D) front elevation

42. Which of the following is NOT a stage of the design process?

- (A) Synthesis
- (B) Evaluation
- (C) Presentation
- (D) Coordination

43. In the design process, recognition of need means

- (A) having persons in need of help
- (B) realizing that a design is complete
- (C) establishing that a component is to be designed
- (D) recognising that needy people always have to be fed

44. In the design process, optimization is

- (A) ensuring all the design parts fit
- (B) testing a design for best results
- (C) revealing all the features of the design
- (D) creating all the ideas needed to complete the design

Item 45 refers to the following diagram of a force system.

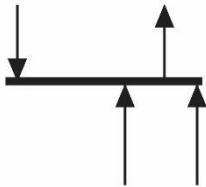

45. Which type of force system is represented?

- (A) Parallel
- (B) Coplanar
- (C) Structured
- (D) Concurrent

END OF TEST



C A R I B B E A N E X A M I N A T I O N S C O U N C I L

C A R I B B E A N A D V A N C E D P R O F I C I E N C Y E X A M I N A T I O N ®

M E C H A N I C A L E N G I N E E R I N G D R A W I N G A N D D E S I G N

Unit 2 – Paper 02

2 hours 30 minutes

SPECIMEN PAPER

GENERAL INFORMATION

- 1. This paper consists of SIX questions.**
- 2. Answer ALL questions from EACH section.**
- 3. EACH question is worth 20 marks. You are advised to spend approximately 25 minutes on each question.**
- 4. Silent, non-programmable calculators may be used for this examination.**
- 5. For this examination, each candidate should have:**
 - Two sheets of drawing paper (both sides may be used)**
 - Two sheets of graph paper**
 - Drawing board and T-square**
 - Two sheets of tracing paper**
 - Drawing instruments**
 - Data sheet B.S.4500 (both hole and shaft basis), provided as an insert**

INSTRUCTIONS TO CANDIDATES

- 1. All dimensions given are in millimetres unless otherwise stated.**
- 2. Where scales are not stated the full size should be applied.**
- 3. All geometrical construction lines MUST be visible on all drawings.**
- 4. When first-angle or third-angle is not specified, the choice of projection is left to the candidate's discretion, in which case the type of projection used MUST be clearly stated.**
- 5. The candidate should use his/her own judgement to supply any dimensions or other details not directly shown on the drawings.**
- 6. The number of EACH question MUST be written next to the solution.**
- 7. Each candidate MUST enter his/her school code and registration number in the appropriate space at the bottom of the drawing paper.**

SECTION A

MODULE 1

MECHANICS OF MACHINES

Answer ALL questions from this section.

1. Figure 1 shows a simply supported beam with two concentrated loads of 20 kN and 10 kN.

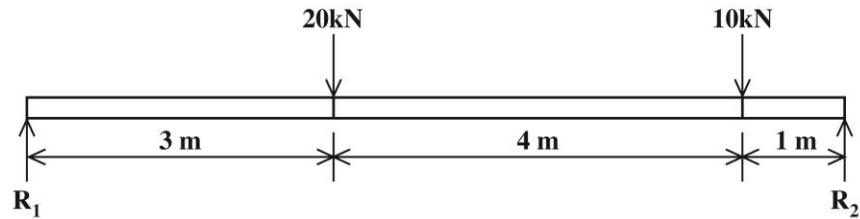

Figure 1. Supported beam

- (a) Find graphically the magnitude of the reactions R_1 and R_2 . [15 marks]
- (b) Verify analytically the magnitude of the reactions R_1 and R_2 . [5 marks]

Total 20 marks

2. (a) Figure 2 shows the parts of a spur gear.

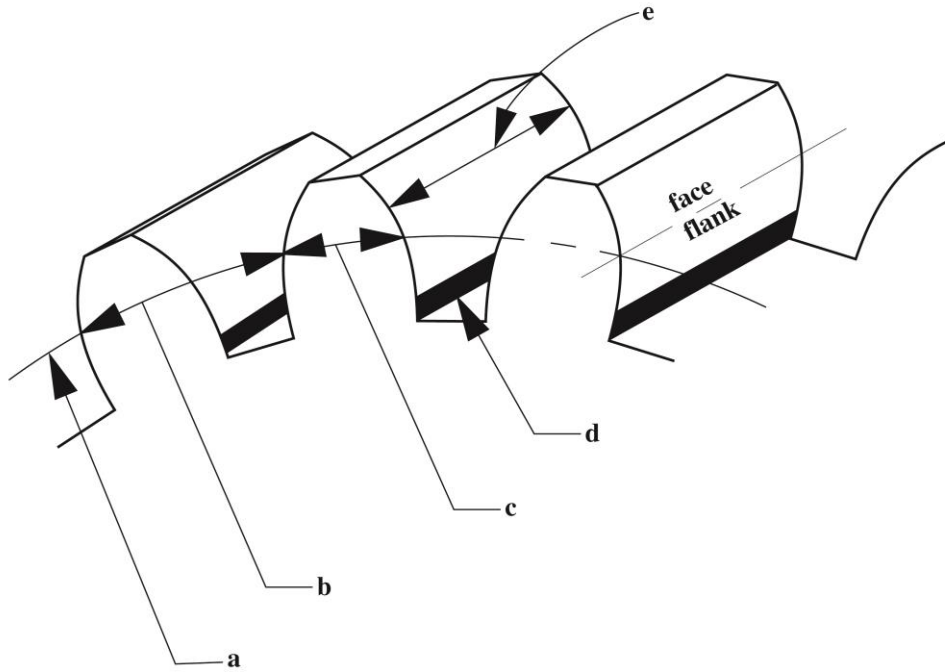

Figure 2. Parts of a spur gear

- (i) Sketch freehand the THREE consecutive teeth of the spur gear. **[3 marks]**
- (ii) Name and label the terms associated with a, b, c, d and e. **[7 marks]**

- (b) The letter "A" (**not shown**) casts shadows on the horizontal plane and vertical plane as shown in figure 3.

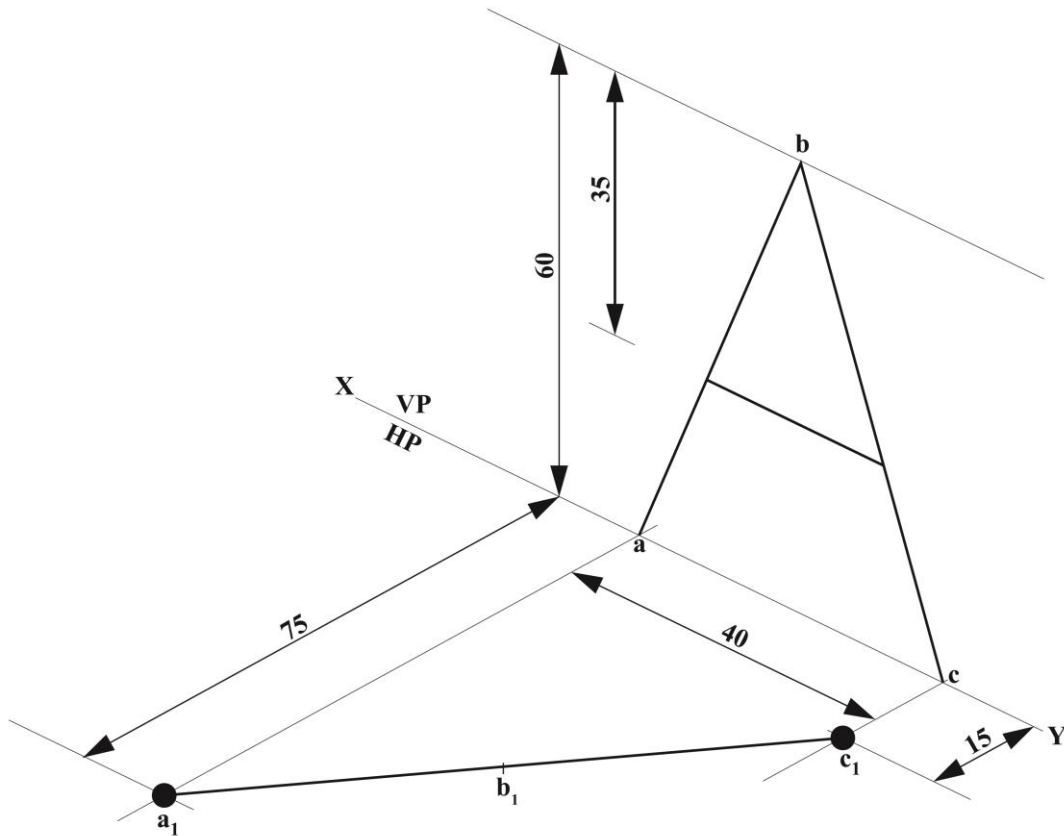

Figure 3. Shadow of letter "A"

- (i) Construct the true shape of the letter "A". [5 marks]
- (ii) Determine the size of angle abc of the letter. [5 marks]

Total 20 marks

SECTION B

MODULE 2

ENGINEERING MATERIALS AND PROCESSES

Answer ALL questions from this section.

3. Figure 4 shows a cylinder head.



Figure 4

- (a) Sketch the seal that would be used when mounting the head.
- (b) Name the seal.
- (c) Of what material would the seal be made?
- (d) List TWO steps that would be taken when properly installing seals.

Total 20 marks

4. (a) Describe EACH of the following:
- (i) Ferrous metals
 - (ii) Grey cast iron
 - (iii) Carbon steel
- (b) Give the carbon content, principal properties and the common uses of the following types of steel:
- (i) Low carbon
 - (ii) High carbon
- (c) Give the principal property and ONE common use of TWO of the following types of alloy steel:
- (i) Molybdenum
 - (ii) Chromium
 - (iii) Chromium-vanadium
- (d) Describe the following plastics and give ONE example of EACH:
- (i) Thermoplastics
 - (ii) Thermosetting plastics

Total 20 marks

SECTION C

MODULE 3

MANAGEMENT AND DESIGN

Answer ALL questions from this section.

5. Figure 5 shows two sections of an automotive brake system, Section A and Section B. Section A is showing the portion of the brake that is inside the automotive and Section B is showing the portion where the wheel is situated.

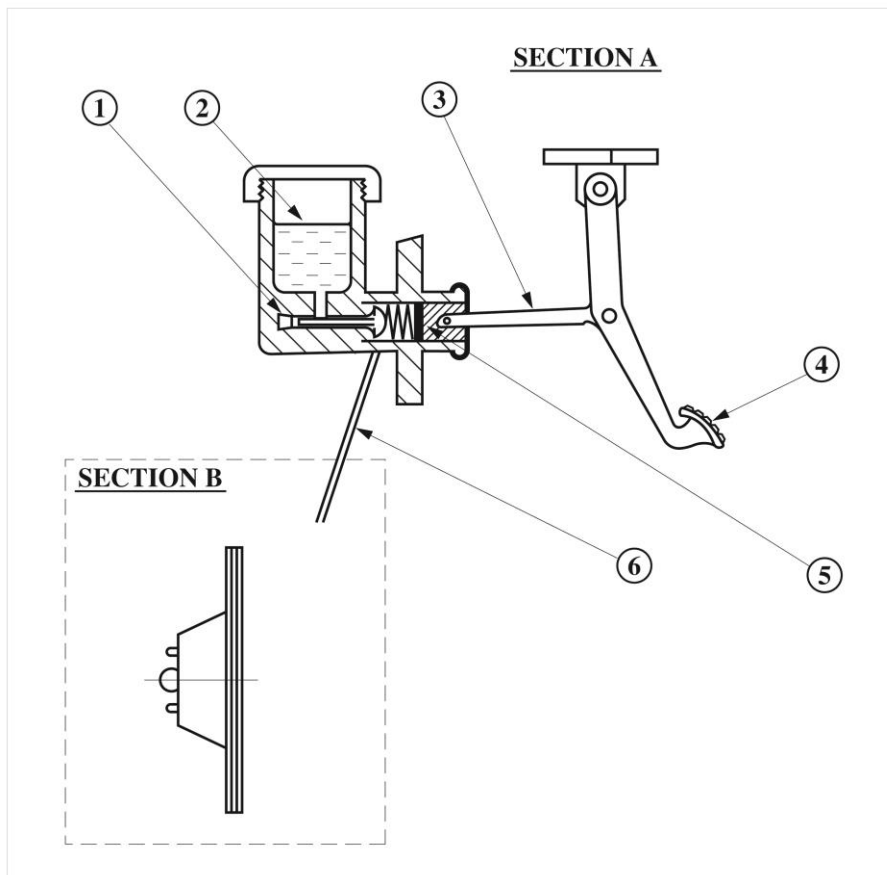

Figure 5

- (a) Write the numbers 1, 2, 3, 4, 5 and 6, and next to EACH number write the name of the corresponding part.
- (b) Complete the drawing in Section B showing the cross-sectional view of a disc brake. Fully label the drawing.
- (c) Explain how the disc brake works.

Total 20 marks

6. (a) With the aid of a neat, labelled pictorial sketch, show the construction of a flanged coupling. **[12 marks]**
- (b) State THREE reasons why the coupling mentioned in (a) can be used to connect a motor and generator. **[6 marks]**
- (c) Explain TWO different ways in which flaws or defects in the flanged coupling system can be identified. **[2 marks]**

Total 20 marks

END OF TEST

IF YOU FINISH BEFORE TIME IS CALLED, CHECK YOUR WORK ON THIS TEST.

C A R I B B E A N E X A M I N A T I O N S C O U N C I L

ADVANCED PROFICIENCY EXAMINATION

**BUILDING AND MECHANICAL ENGINEERING DRAWING
OPTION B - BUILDING DRAWING AND DESIGN**

UNIT 2 – Paper 02

2 hours 30 minutes

SPECIMEN PAPER

GENERAL INFORMATION

1. This paper consists of SIX questions.
2. Answer ALL questions from EACH section.
3. EACH question is worth 20 marks. You are advised to spend approximately 25 minutes on each question.
4. Silent, non-programmable calculators may be used for this examination.
5. For this examination, each candidate should have:
Two sheets of drawing paper (both sides may be used)
Drawing board and T-square
Drawing instruments
Data sheet B.S.4500 (both hole and shaft basis), provided as an insert

INSTRUCTIONS TO CANDIDATES

1. All dimensions given are in millimetres unless otherwise stated.
2. Where scales are not stated the full size should be applied.
3. All geometrical construction lines MUST be visible on all drawings.
4. When first-angle or third-angle is not specified, the choice of projection is left to the candidate's discretion, in which case the type of projection used MUST be clearly stated.
5. The candidate should use his/her own judgement to supply any dimensions or other details not directly shown on the drawings.
6. The number of EACH question MUST be written next to the solution.
7. Each candidate MUST enter his/her school code and registration number in the appropriate space at the bottom of the drawing paper.

SECTION A
MODULE 1
STRUCTURAL DRAWINGS

Answer ALL questions from this section.

1. Figure 1 shows a simply supported beam with two concentrated loads of 20 kN and 10 kN.

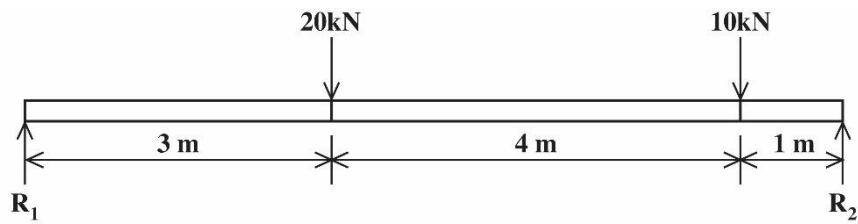

Figure 1. Supported beam

- (a) Find graphically the magnitude of the reactions R_1 and R_2 . **[15 marks]**
- (b) Verify analytically the magnitude of the reactions R_1 and R_2 . **[5 marks]**

Total 20 marks

2. Figure 2 shows a plan of a round column and the footing that supports the column.

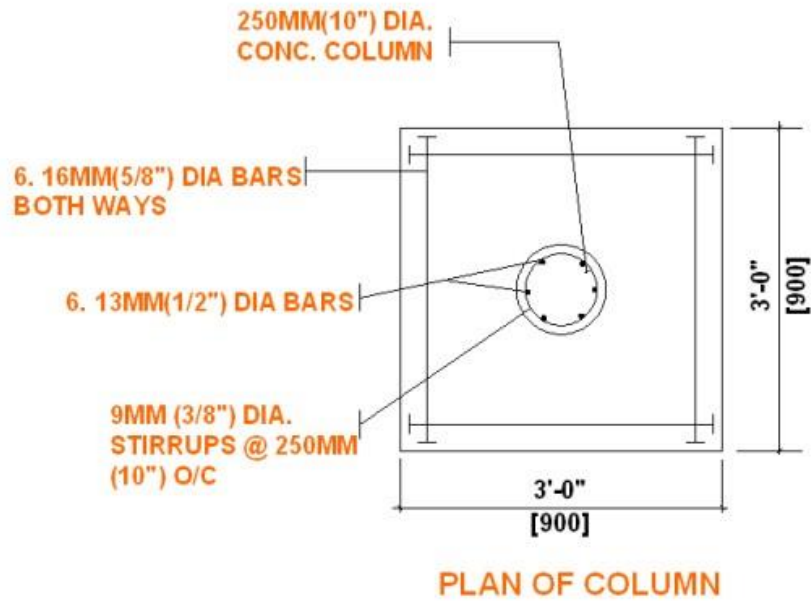

Figure 2. Plan of column

- (a) Produce a well-proportioned sketch showing a section through the column and footing. All dimensions and specifications should be included. **[15 marks]**
- (b) Sketch the plan view of EACH of the following.
- (i) An 'L' corner stiffener detail
 - (ii) A 'T' corner stiffener detail **[5 marks]**

Total 20 marks

SECTION B

MODULE 2

BUILDING MATERIALS AND PROCESSES

Answer ALL questions from this section.

3. Concrete is the most widely used construction material, careful preparation of concrete mixes is essential to the structural integrity of concrete structures.
- (a) Explain the importance of batching/proportioning when preparing a concrete mix. **(4 marks)**
 - (b) Define the term water-cement (w/c) ratio. **(1 mark)**
 - (c) Explain how the water-cement (w/c) ratio affect the concrete mix. **(3 marks)**
 - (d) Explain the term hydration as it relates to concrete. **(2 marks)**
 - (e) Sketch two methods of connecting treads and risers on a timber staircase. Hatching is required **(10 marks)**

Total 20 marks

4. Figure 3 shows a reinforced concrete slab that covers a room 4.5 meters wide and 4.8 meters long. The slab has a 300 mm cantilever.

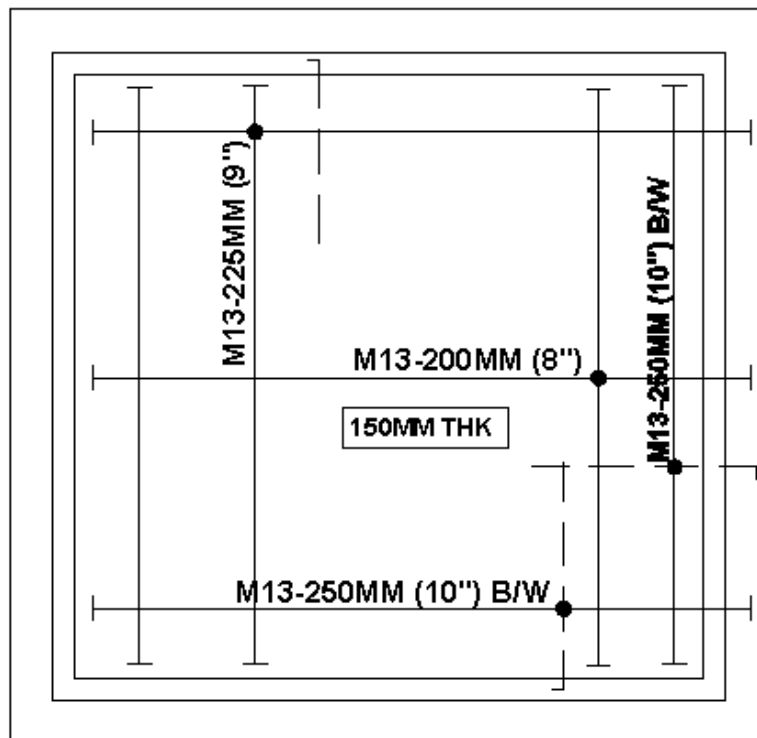

Using a scale of 1:20, draw a cross-section through the concrete slab.

ALL dimensions and specifications should be included.

(20 marks)

SECTION C

MODULE 3

MANAGEMENT AND DESIGN

Answer ALL questions from this section.

5. Table 1 shows the activities, their estimated duration and predecessors for a construction project.

TABLE 1: ACTIVITIES FOR A CONSTRUCTION PROJECT

Activity	Duration	Predecessors
A Drill well	3	--
B Power line	5	A
C Excavate	7	A
D Order & deliver materials	3	B, C
E Pump house	5	B
F Install pipe	4	D
G Foundation	2	C
H Assemble tank	5	E, F, G

- (a) Construct the project activity network using AOA methodology. Label EACH node and arrow appropriately. **(8 marks)**
- (b) Determine the duration of the project. **(4 marks)**
- (c) Calculate the early start, early finish, latest start, latest finish and slack time for EACH activity. **(8 marks)**

Total 20 marks

6. (a) Using the six stages of the design process, explain how the design of a two storey apartment building is conceptualized. **[18 marks]**
- (b) Explain how the design principle of aesthetics would Impact on the apartment building in (a) above. . **[2 marks]**

Total 20 marks

END OF TEST

IF YOU FINISH BEFORE TIME IS CALLED, CHECK YOUR WORK ON THIS TEST.

Unit 1 – Paper 01 Option A – Engineering Drawing

No.	Syllabus Ref.	Module	Key
1.	1:1:1 b	1	B
2.	1:1:1 b	1	D
3.	1:2:3	2	C
4.	1:1:2	1	C
5.	1:2:5	2	B
6.	1:1:b	1	B
7.	1:1:2	1	D
8.	1:1:2	1	B
9.	1:1:2	1	B
10.	2:5:a	2	A
11.	2:4:a	2	D
12.	1:1:3	1	A
13.	1:1:4: a	1	A
14.	1:1:4:C	1	A
15.	1:1:3:b	1	B
16.	1:2:2:c	2	C
17.	1:1:1(iv)	1	B
18.	1:2:2	2	D
19.	1:1:b (i)	1	C
20.	1:1:1	1	D
21.	1:1:1	1	A
22.	1:1:3	1	A
23.	1:2:2	2	B
24.	1:2:4	2	B
25.	1:2;4	2	C
26.	1:2:1 a	2	A
27.	1:2:1	2	D
28.	1:2:5	2	C
29.	1:2:5	2	B
30.	1:2:1 a	2	C
31.	1:3A: 3	3A	D
32.	1:3A:7 a	3A	D
33.	1:3A:3	3A	D
34.	1:3A:3	3A	B
35.	1:3A:3	3A	C
36.	1:3A:5 d	3A	C
37.	1:3A:5 d	3A	D
38.	1:3A:7 c	3A	C
39.	1:3A:7 c	3A	B
40.	1:3A:7 c	3A	C
41.	1:3A:5	3A	A
42.	1:3A:5	3A	A
43.	1:3A:5	3A	A
44.	1:3A:7 b	3A	A
45.	1:3A:6 f	3A	D

Unit 1 – Paper 01 Option B Building Drawing

No.	Syllabus Ref.	Module	Key
1.	1:1:1 b	1	B
2.	1:1:1 b	1	D
3.	1:2:3	2	C
4.	1:1:2	1	C
5.	1:2:5	2	B
6.	1:1:b	1	B
7.	1:1:2	1	D
8.	1:1:2	1	B
9.	1:1:2	1	B
10.	2:5:a	2	A
11.	2:4:a	2	D
12.	1:1:3	1	A
13.	1:1:4: a	1	A
14.	1:1:4:C	1	A
15.	1:1:3:b	1	B
16.	1:2:2:c	2	C
17.	1:1:1(iv)	1	B
18.	1:2:2	2	D
19.	1:1:b (i)	1	C
20.	1:1:1	1	D
21.	1:1:1	1	A
22.	1:1:3	1	A
23.	1:2:2	2	B
24.	1:2:4	2	B
25.	1:2;4	2	C
26.	1:2:1 a	2	A
27.	1:2:1	2	D
28.	1:2:5	2	C
29.	1:2:5	2	B
30.	1:2:1 a	2	C
31.		3B	D
32.	1:3B:3	3B	D
33.	1:3B:3	3B	C
34.	1:3B:3 b	3B	C
35.	1:3B:3 b	3B	A
36.	1:3B:2	3B	C
37.	1:3B:3	3B	B
38.	1:3B:3 e	3B	A
39.	1:3B:3 e	3B	A
40.	1:3A:2 b	3B	B
41.	1:3A:2 a	3B	D
42.	1:3B:4 g	3B	A
43.	1:3B:1	3B	C
44.	1:3B:3	3B	A
45.	1:3B:3	3B	C

02168020/CAPE/MS 2015

C A R I B B E A N E X A M I N A T I O N S C O U N C I L

CARIBBEAN ADVANCED PROFICIENCY EXAMINATION®

BUILDING AND MECHANICAL ENGINEERING DRAWING

UNIT 1 – PAPER 02

MARK SCHEME

MAY/JUNE 2015

Building and Mechanical Engineering Drawing
Unit 1 Paper 02
Mark Scheme
May/June 2015

SECTION A

Question 1

Criteria

- Identified and drew the relative positions of the focus and directrix
- Got the intersection points of Radii with lines drawn parallel
- Drew a neat curve passing through the intersection points.

K	A	DS
	1	1
1	1	1
1	2	2

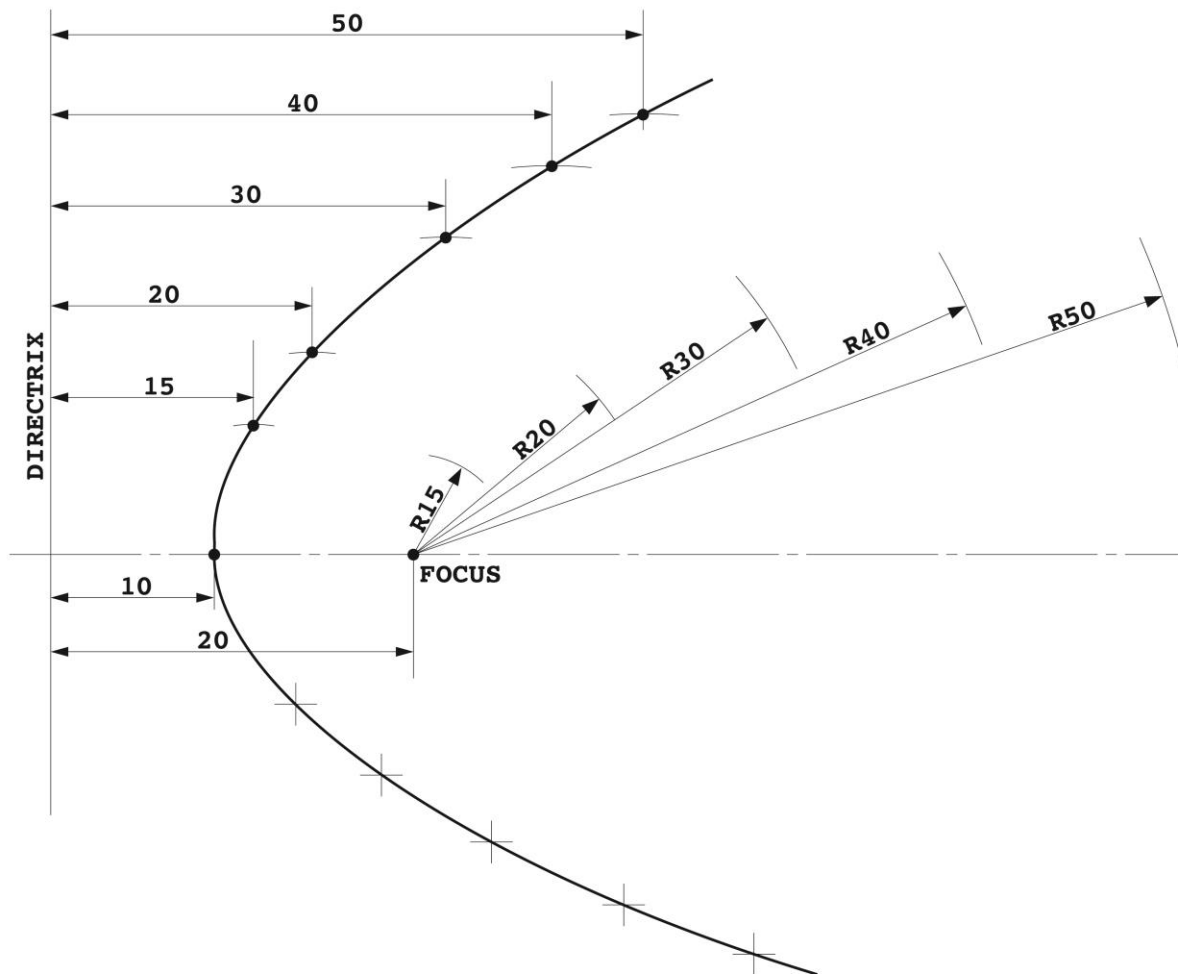

Building and Mechanical Engineering Drawing
 Unit 1 Paper 02
 Mark Scheme
 May/June 2015

Question 1 cont'd

Criteria

- (b) (i)
- Drew OP = 50 mm (length) and located the shortest length", 10 mm with 'O' as centre.
 - Divided the angular movement of one revolution and corresponding linear distance travelled into 12 equal Darts (say)
 - Plotted a smooth Archimedean curve passing through the points
- (ii)
- Drew a normal and tangent
 - Located the given point of 25 mm from the pole on the curve.

K	A	DS
1	1	1
	2	2
	1	1
1		1
2	4	5

SECTION A

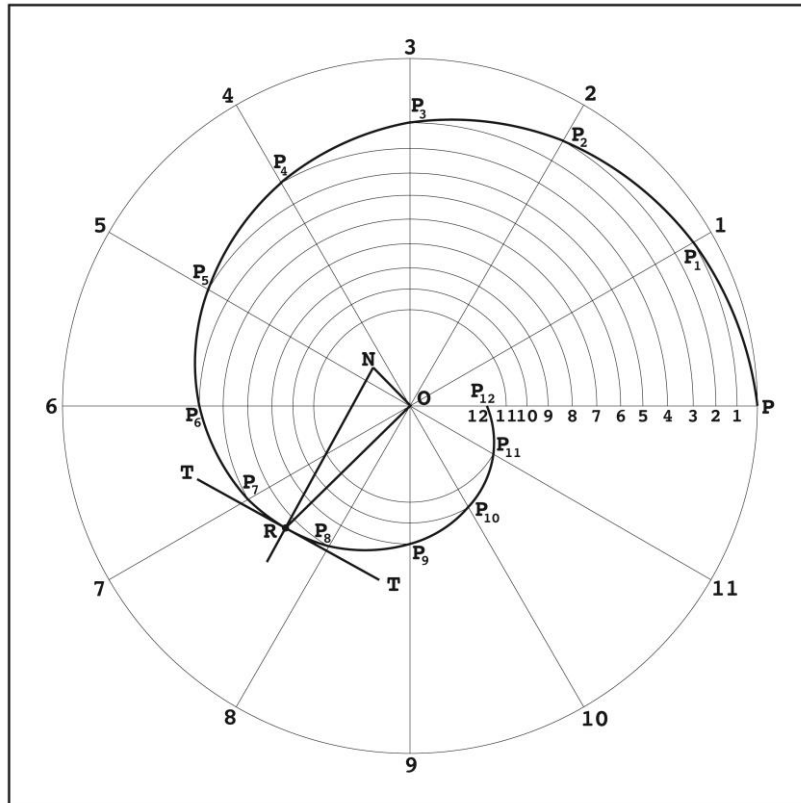

Building and Mechanical Engineering Drawing
Unit 1 Paper 02
Mark Scheme
May/June 2015

Question 1 cont'd

Criteria

- (c)
- Draw a freehand sketch
 - Labelled the required features

K	A	DS
1	1	1
	1	
1	2	1

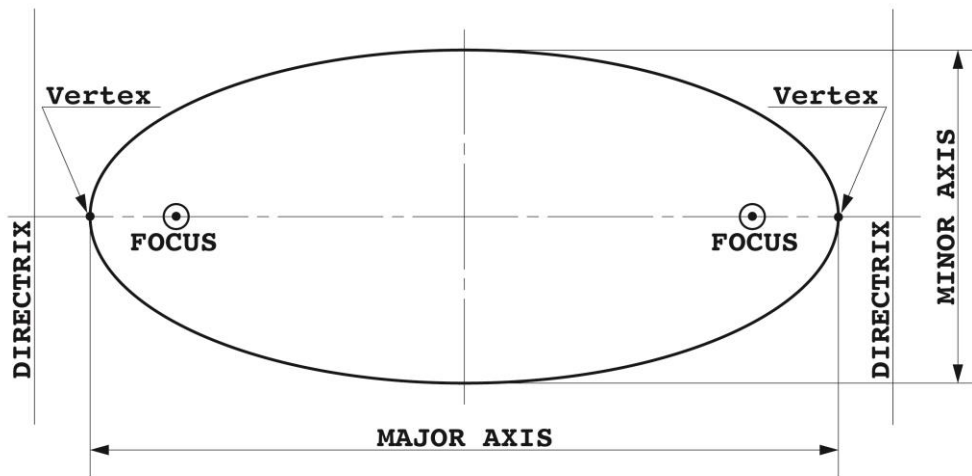

Building and Mechanical Engineering Drawing
Unit 1 Paper 02
Mark Scheme
May/June 2015

Question 2

Criteria		K	A	DS
(a)	Reproduced cam	1	1	2
(b)	Drew performance diagram	1	2	1
	Transferred performance Drew curve	1	2	2
(c)	Fully label the drawing		1	1
(d)	Identified dwell	2	1	
(e)	Non-symmetrical curve (explanation)	1	1	
TOTAL		6	8	6

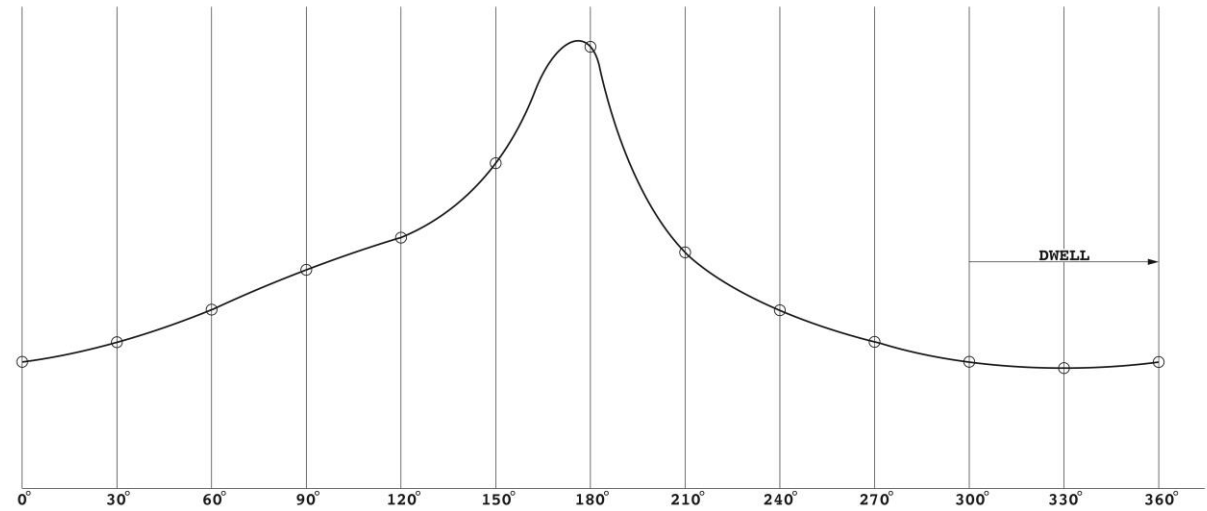
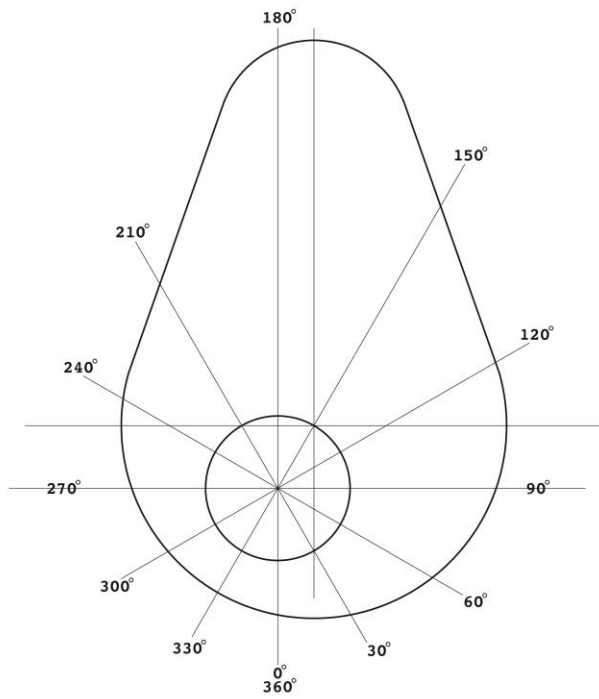

PERFORMANCE DIAGRAM

(c) The dwell period is between 300°

(d) Curve is not symmetrical because camshaft is off centre

Building and Mechanical Engineering Drawing
 Unit 1 Paper 02
 Mark Scheme
 May/June 2015

Question 3

SOLUTION

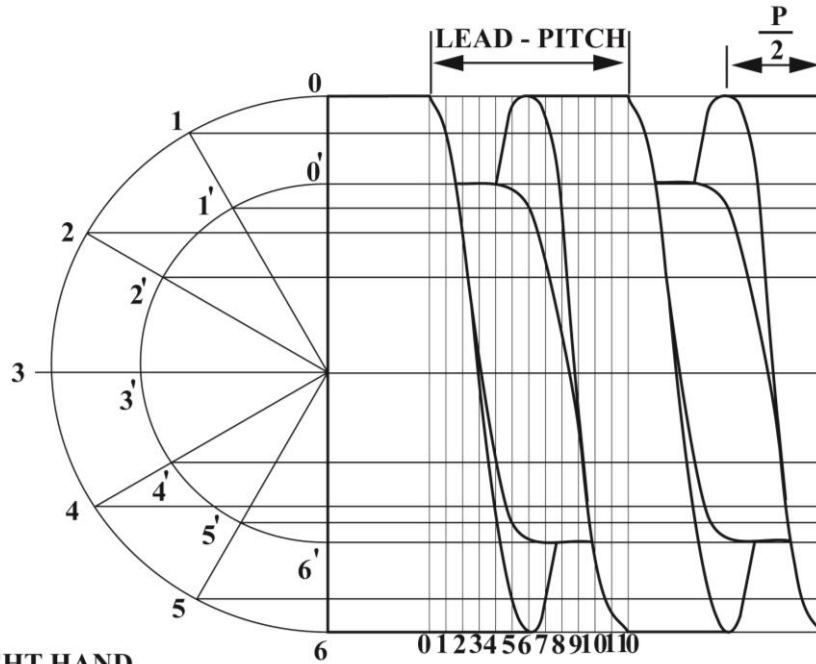

**RIGHT HAND
 SQUARE THREAD
 SINGLE START**

MODULE 2

	CRITERIA	K	A	DS
	Draw base line and vertical and mark off two diameters.			2
	Draw semi-circles for the two diameters, divide and project horizontally.	1	1	1
	Mark off leads (pitches), divide and project vertically	1	1	1
	(i) Plot points and join with smooth curve.	3	6	3
	(ii) Plot points and join with smooth curve.			
	(iii) Plot points and join with smooth curve.			
	(iv) Plot points and join with smooth curve.			
		5	8	7

Building and Mechanical Engineering Drawing
 Unit 1 Paper 02
 Mark Scheme
 May/June 2015

Question 4

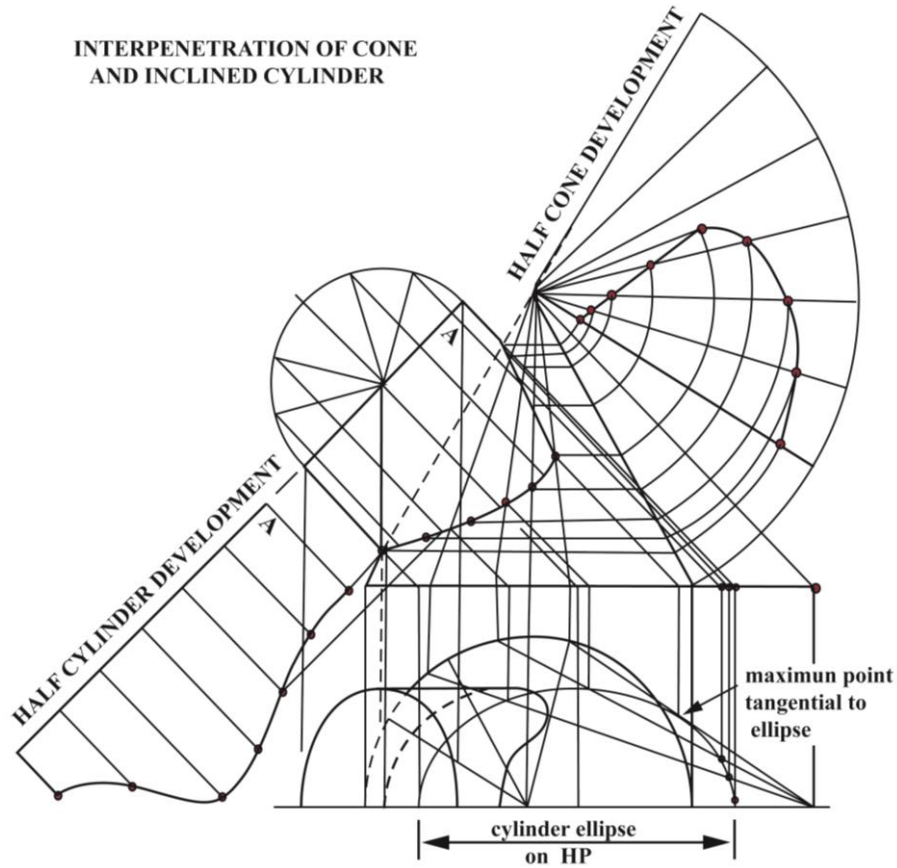

	CRITERIA	K	A	DS
	Reproduce figure			1
	Draw Plan	1	2	1
	Draw elevation	2	1	2
	Draw auxiliary plan	2	2	2
	Draw curve of interpenetration.	1	1	2
		6	6	8

Building and Mechanical Engineering Drawing
Unit 1 Paper 02
Mark Scheme
May/June 2015

Question 5

Solution

Definitions

- (a) Design a mechanism which allows the rigid stool to swivel
- (b) Any THREE ideas
- (c) Any good design:

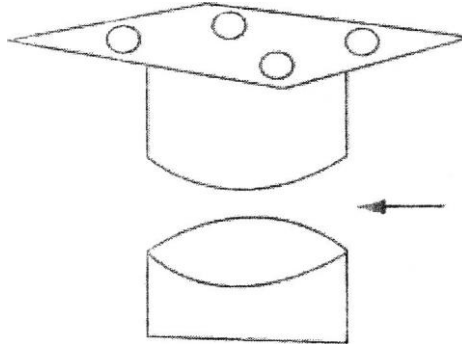

- (d) Material steel: Strong, machinable, needs coating, may rust.

	CRITERIA	K	A	DS
	Defined the problem	1	2	
	Suggested solution (THREE)	2	3	3
	Detailed Design	1	2	3
	Chose material and evaluate	1	2	
		5	9	6

Building and Mechanical Engineering Drawing
Unit 1 Paper 02
Mark Scheme
May/June 2015

Question 6

SOLUTION

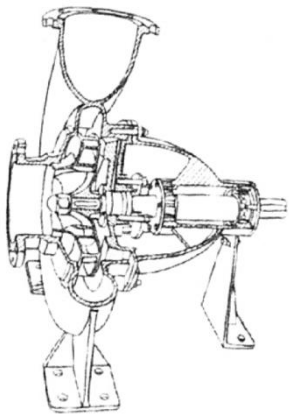
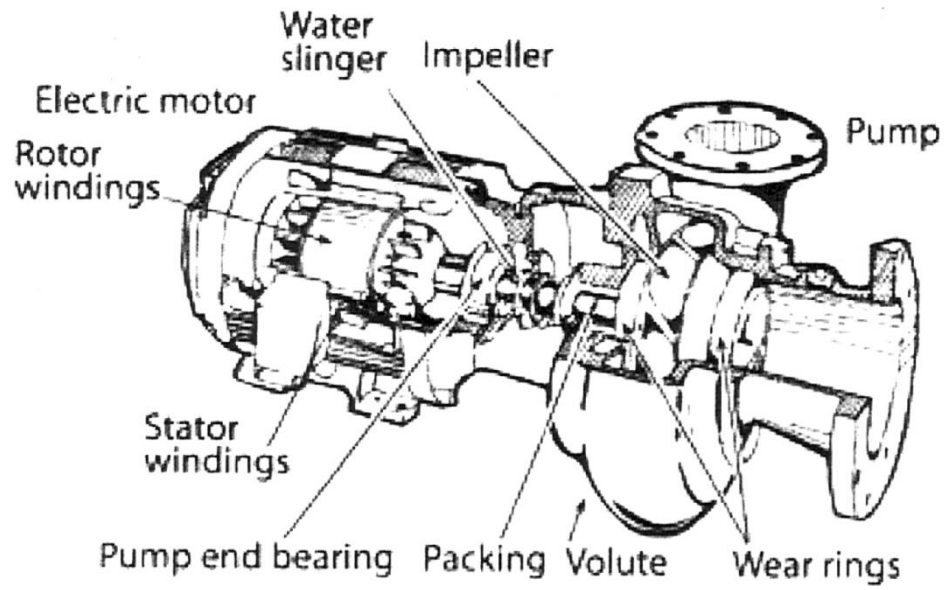

(a) } [See drawings]
(b) }

Building and Mechanical Engineering Drawing
Unit 1 Paper 02
Mark Scheme
May/June 2015

(c) Move water or air for irrigation or ventilation

QUESTION 6 (cont'd)

MARK SCHEME

CRITERIA		K	A	DS
(a)	Sketch pump correctly	1	2	1
	Cut-away view		1	1
	Sketch motor correctly	1	2	1
	Show method of coupling	1		
	Free hand construction		1	2
	Good proportion			2
(b)	Label components	1	2	
(c)	Give application		1	
		4	9	7

Building and Mechanical Engineering Drawing
Unit 1 Paper 02
Mark Scheme
May/June 2015

Question 7

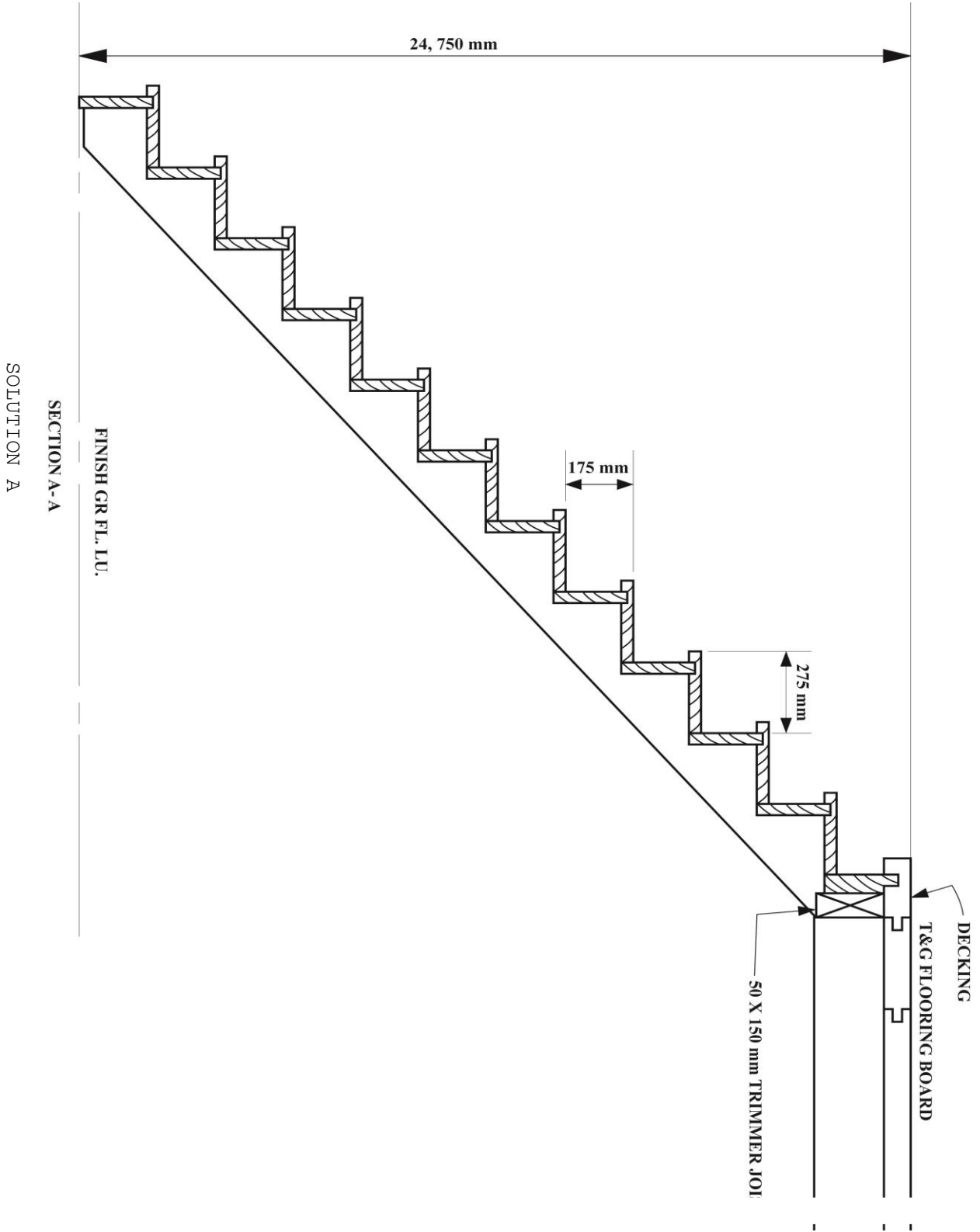

Building and Mechanical Engineering Drawing
 Unit 1 Paper 02
 Mark Scheme
 May/June 2015

Question 7 (cont'd)

SOLUTION B

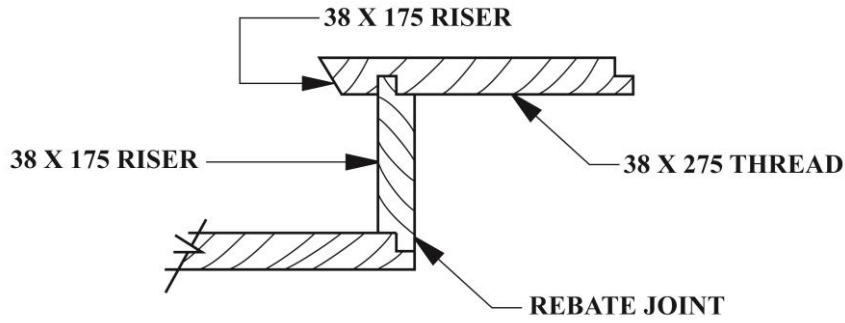

Criteria	K	A	DS	Total
(a) - Outline of decking and ground floor	1		1	
- Equal division of risers to suit height	1	1	1	
- Sectional view of threads and risers with trimmer joint		2	4	
- Hatching lines		2		
- Labeling of members		2		
(b) Construction Joint				
- Sectional view of joint at junction	1	1	2	
- Labeling of members		1		
	3	9	8	20

Building and Mechanical Engineering Drawing
Unit 1 Paper 02
Mark Scheme
May/June 2015

Question 8

SOLUTION

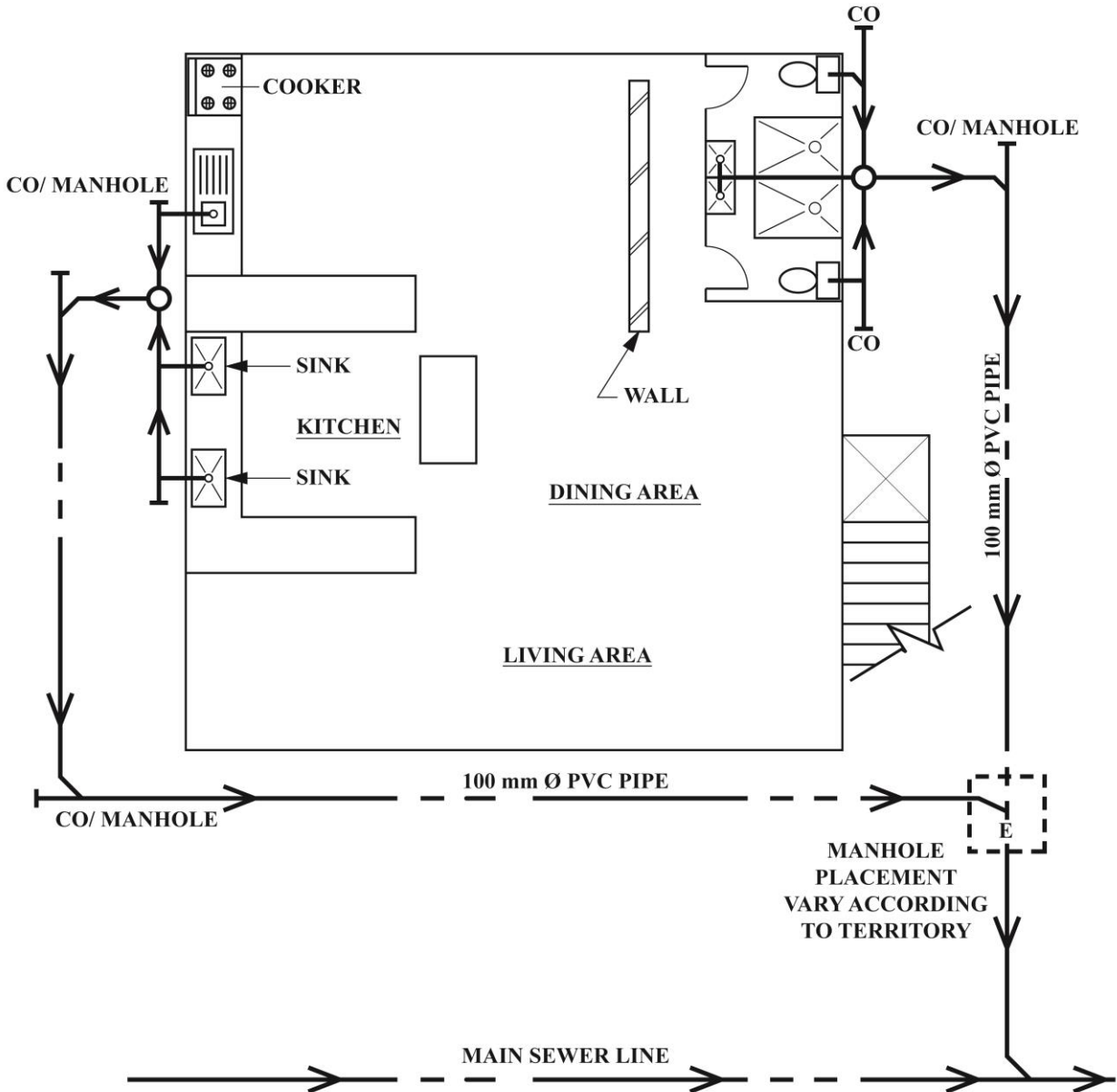

Building and Mechanical Engineering Drawing
Unit 1 Paper 02
Mark Scheme
May/June 2015

Question 8 (cont'd)

Criteria	K	A	DS	Total
Layout of existing upper floor plan in proportion	1	2	2	
Plumbing fixtures on layout		1	2	
Main sewer line		1	1	
Identification of flow from fixtures to main stack	1	2	2	
Connection of property pipe to main sewer line	1	1	1	
Labeling of structures and fitting		2		
	3	9	8	20

BMED MDS Unit2 Option A - Mechanical Engineering Drawing and Design

No.	Syllabus Ref.	Module	Key
1.	2A:1:3	1	A
2.	2A:1:3	1	C
3.	2A:2:2	2	D
4.	2A:2:2	2	B
5.	2A:2:2	2	B
6.	2A:2:2	2	D
7.	2A:2:2	2	D
8.	2A:2:2	2	B
9.	2A:2:1 b	2	B
10.	2A:2:2	2	B
11.	2A:2:2	2	C
12.	2A:2:2	2	C
13.	2A:2:2 c	2	A
14.	2A:2:3 c	2	D
15.	2A:2:3 c	2	A
16.	2A:3:3	3	D
17.	2A:3:3	3	C
18.	2A:3:3	3	B
19.	2A:1:2	1	A
20.	2A:1:2	1	C
21.	2A:1:2	1	C
22.	2A:3:4 a	3	D
23.	2A:1:1 b	1	C
24.	2A:2:1 b	2	C
25.	2A:2:3 a	2	B
26.	2A:3:1	3	B
27.	2A:1:1 a	1	D
28.	2A:1:1 a	1	B
29.	2A:1:1 a	1	A
30.	2A:2:1 c	2	D
31.	2A:2:4 b	2	A
32.	2A:3:4 b	3	A
33.	2A:3:4 b	3	B
34.	2A:3:4 b	3	B
35.	2A:2:3	2	C
36.	2A:3:1	3	A
37.	2A:3:1	3	A
38.	2A:1:3	1	D
39.	2A:1:3	1	C
40.	2A:1:3	1	B
41.	2A:1:3	1	A
42.	2A:1:1	1	D
43.	2A:1:2	1	A
44.	2A:3:2	3	A
45.	2A:3:2	3	C

Unit 2 – Paper 01 Option B Building Drawing and Design

No.	Syllabus Ref.	Module	Key
1.	2B:2:1 j	2	B
2.	2B:2:1 j	2	D
3.	2B:2:1 j	2	C
4.	2B:1:1	1	D
5.	2B:1:2	1	B
6.	2B:3:1 a	3	A
7.	2B:3:1 a	3	C
8.	2B:3:1 a	3	B
9.	2B:3:1 a	3	A
10.	2B:3:1 b	3	D
11.	2B:1:1	1	B
12.	2B:1:1	1	D
13.	2B:1:2	1	A
14.	2B:3:2	3	C
15.	2B:3:2	3	A
16.	2B:3:1	3	C
17.	2B:2:2	2	A
18.	2B:2:2	2	C
19.	2B:2:3	2	A
20.	2B:3:3:	3	D
21.	2B:2:1	2	B
22.	2B:2:1 e	2	A
23.	2B:2:1 e	2	B
24.	2B:2:1 h	2	D
25.	2B:2:2 d	2	D
26.	2B:2:3 b	2	A
27.	2B:2:3 a	2	D
28.	2B:2:7 a	2	A
29.	2B:1:1 a	1	B
30.	2B:1:1 a	1	A
31.	2B:2:1 f	2	B
32.	2B:3:1	3	D
33.	2B: 3: 4	3	D
34.	2B:1:4 f	1	A
35.	2B:1:4	1	B
36.	2B:1:4 f	1	B
37.	2B:1:4 f	1	A
38.	2B:1:1	1	C
39.	2B:3:4	3	B
40.	2B:2:4 d	2	A
41.	2B:1:1	2	A
42.	2B:3:2	3	D
43.	2B:3:2	3	C
44.	2B:3:2	3	B
45.	2B:1:1	1	A

02268020/SPEC/2015

C A R I B B E A N E X A M I N A T I O N S C O U N C I L

CARIBBEAN ADVANCED PROFICIENCY EXAMINATION

MECHANICAL ENGINEERING DRAWING AND DESIGN

SPECIMEN PAPER

UNIT 2 - PAPER 02

SOLUTIONS AND MARK SCHEME

MECHANICAL ENGINEERING DRAWING AND DESIGN
UNIT 2 – PAPER 02
SOLUTIONS AND MARK SCHEME

Question 1

	CRITERIA	K	A	DS
(a)	Drew the beam and loads to a convenient scale			1
	Drew the polar polygon	2	3	2
	Found the reactions	2	2	3
(b)	Compute the reactions analytically	1	4	
	TOTAL	5	9	6

MECHANICAL ENGINEERING DRAWING AND DESIGN
UNIT 2 – PAPER 02
SOLUTIONS AND MARK SCHEME

Question 1 Cont'd

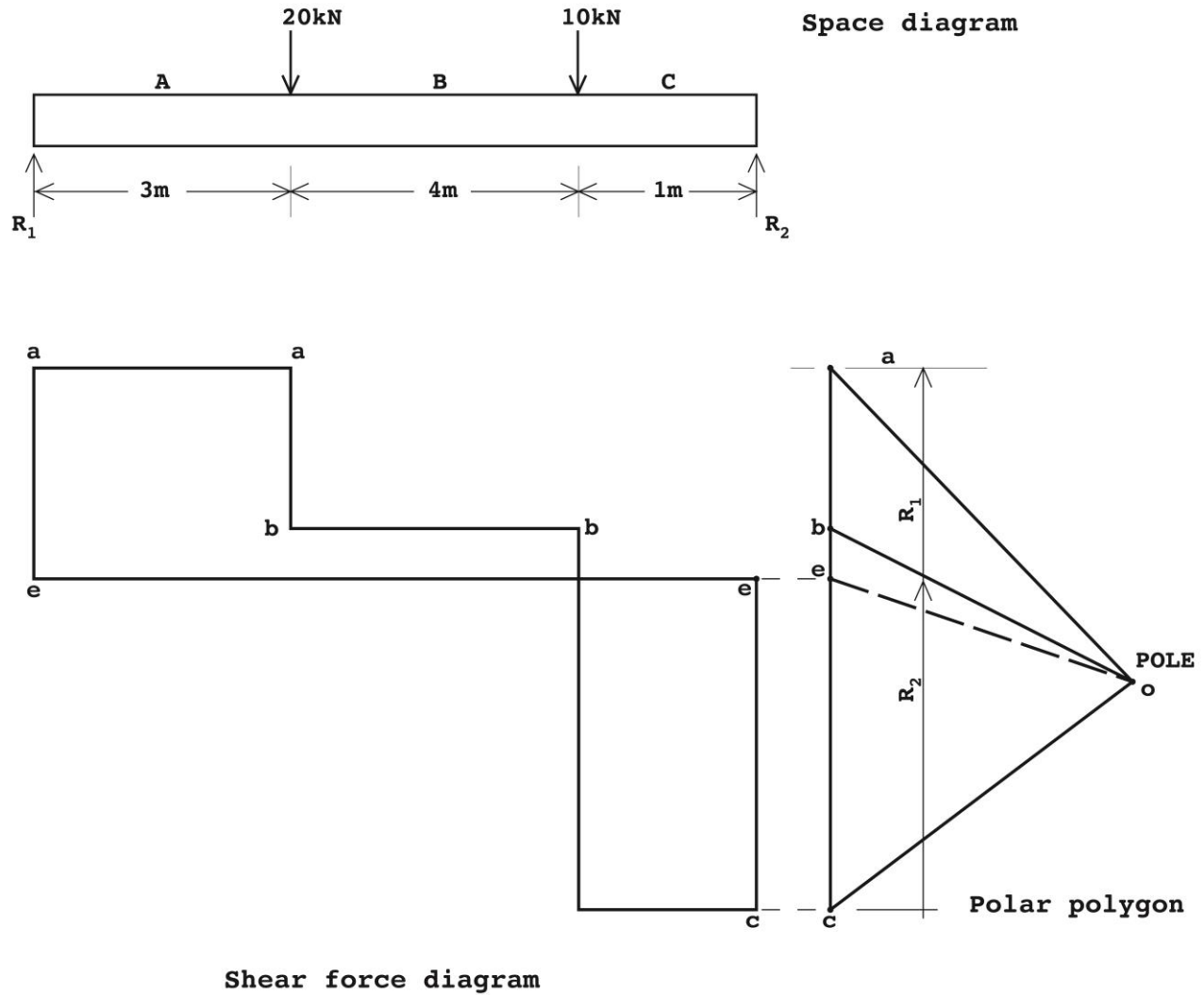

MECHANICAL ENGINEERING DRAWING AND DESIGN
UNIT 2 – PAPER 02
SOLUTIONS AND MARK SCHEME

Question 2

(a)

		CRITERIA		
		K	A	DS
(i)	Produced freehand sketch of the three consecutive teeth	5	1	3
(ii)	<ul style="list-style-type: none"> • Identified the terms a-e • Labelled the identified terms 	5	1	1
TOTAL		5	1	4

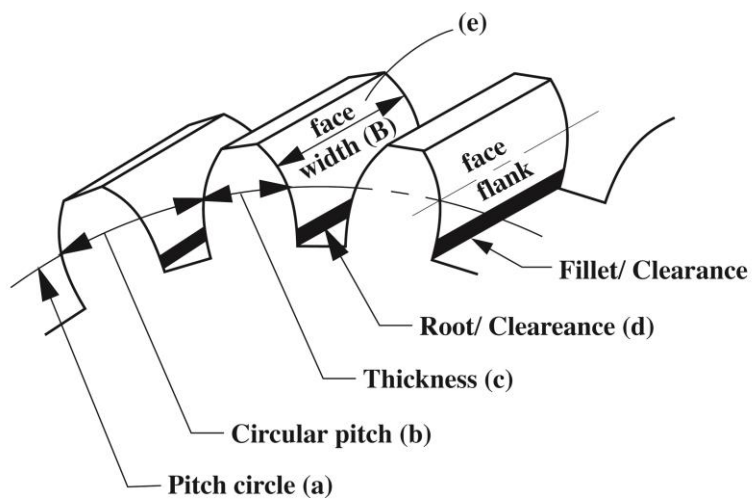

MECHANICAL ENGINEERING DRAWING AND DESIGN
UNIT 2 – PAPER 02
SOLUTIONS AND MARK SCHEME

Question 2 Cont'd

(b)

	CRITERIA	K	A	DS
(i)	Orthographic view	1	1	2
	Auxiliary view		2	2
(ii)	State angle	2		
		3	3	4

MECHANICAL ENGINEERING DRAWING AND DESIGN
UNIT 2 – PAPER 02
SOLUTIONS AND MARK SCHEME

Question 2 cont'd

(c) and (d)

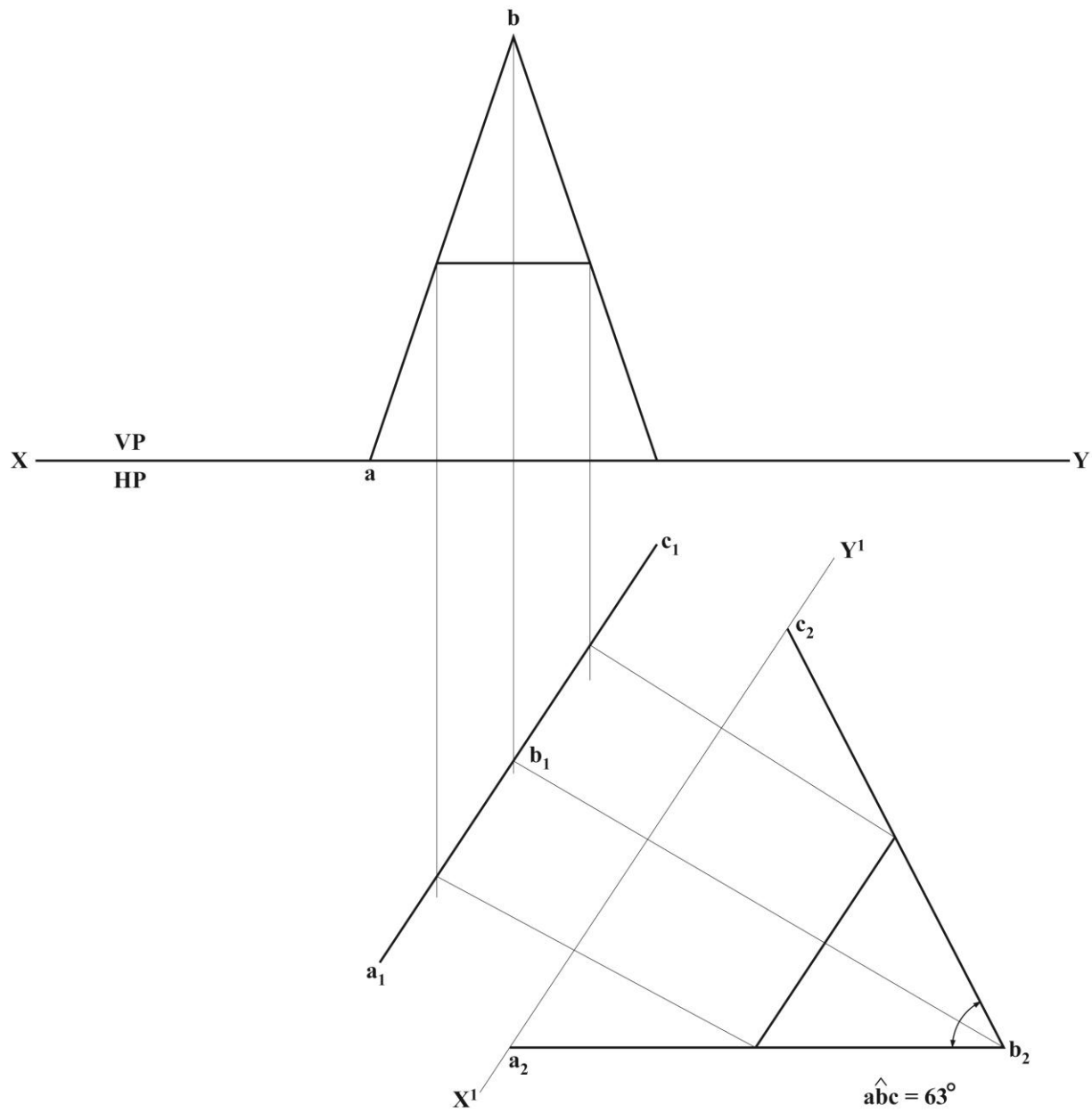

MECHANICAL ENGINEERING DRAWING AND DESIGN
UNIT 2 – PAPER 02
SOLUTIONS AND MARK SCHEME

Module 2

Question 3

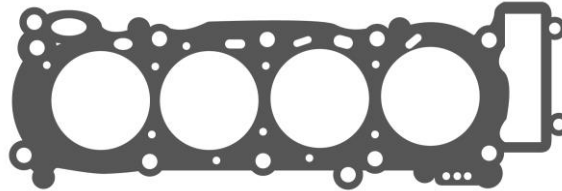

- (a)
- (b) Gasket
- (c) Metal, copper, aluminium, asbestos (obl), cork, rubber
- (d)
1. Ensure seal is flat
 2. Use sealant
 3. Do not over/under tighten
 4. Use correct tightening sequence
 5. Install clean

	CRITERIA	K	A	DS
	Sketch	2	2	2
	Name gasket – type of gasket	1	1	
	Select material	2	2	
	Installation	4	4	
	TOTAL	9	9	2

MECHANICAL ENGINEERING DRAWING AND DESIGN
UNIT 2 – PAPER 02
SOLUTIONS AND MARK SCHEME

Question 4.

SOLUTION

- (a) (i) Ferrous metals are metals that contain iron
- (ii) Gray cast iron is a super saturated solution of carbon in an iron matrix. The excess carbon precipitates out in the form of graphite flakes
- (iii) Carbon steel is essentially an iron – carbon alloy with small amounts of other elements

(b)

Types of carbon steel	Principal properties	Common uses
Low carbon steel (0.06 to 0.20% carbon)	Toughness and less strength	Chains, rivets, shafts and pressed steel products
Higher carbon steel (over 0.50% carbon)	Less toughness and greater hardness	Saws, drills, knives razors, finishing tools and music wire

(c)

Types of steel	Principal properties	Common uses
Molybdenum steel	High strength	Axels, forgings, gears cams, mechanical parts
Chromium steel (stainless steel)	Hardness, great strength and toughness	Gears, shaft, bearings, springs, connecting rods
Chromium – vanadium steel	Hardness and strength	Punches and dies, piston rods, gears, axels

- (d) Thermoplastics – soften or liquify and flow when heat is applied. Removal of heat causes these material to set or solidify. They may be reheated and reformed or reused. Eg. Acrylics, cellulotics, nylons (polyamides), polyethylene, polystyrene, polyfluoro carbons, vinyls.

MECHANICAL ENGINEERING DRAWING AND DESIGN
UNIT 2 – PAPER 02
SOLUTIONS AND MARK SCHEME

Question 4. (cont'd)

Thermosetting plastics – undergo a irreversible chemical change when heat is applied or when a catalyst or reactant is added. They become hard, insoluble and infusible, and they do not soften upon reapplication of heat. Eg. phenolics, amino plastic (melamine and urea) cold molded polyesters, epoxies, silicones, alkyds, allylics, casein.

MARK SCHEME

CRITERIA				K	A	DS
(a)	(i)	Ferrous metals		1	1	
	(ii)	Gray cast iron		1	1	
	(iii)	Carbon steel		1	1	
(b)	(i)	Low carbon steel		2	1	
	(iii)	High carbon steel		2	1	
(c)	(i)	Molybdenum steel	} Any TWO steels. }	1	1	
	(ii)	Chromium steel		1	1	
	(iii)	Chromium-vanadium steel		1	1	
(d)	(i)	Thermoplastics		1	1	
	(ii)	Thermosetting plastics		1	1	
				11	9	

MECHANICAL ENGINEERING DRAWING AND DESIGN
UNIT 2 – PAPER 02
SOLUTIONS AND MARK SCHEME

Module 3

Question 5.

SOLUTION

- (a)
- 1 Relief Valve
 - 2 Reservoir
 - 3 Push Rod
 - 4 Pedal
 - 5 Piston
 - 6 Feed Pipe

(b)

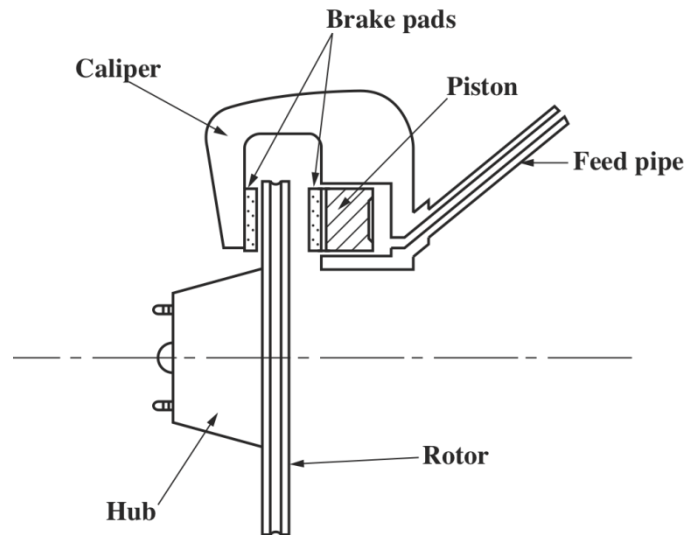

- (c) Pressurized fluid (hydraulics) comes from the feed line when the pedal is depressed, this pressurized fluid pushes the piston as it fills the chamber. This pushing causes the brake pads to squeeze onto the rotor causing the disc to slow down and eventually stop.

MECHANICAL ENGINEERING DRAWING AND DESIGN
UNIT 2 – PAPER 02
SOLUTIONS AND MARK SCHEME

Question 5. (cont'd)

MARK SCHEME

CRITERIA	K	A	DS
(a) Label the points	3	3	
(b) Complete Section B;			
(i) Draw caliper	1		1
(ii) Draw Piston	1		1
(iii) Draw Brake Pads	1		1
(iv) Reproduce Rotor and Hub			1
(v) Label all points	2	2	
(c) Explain how the disc brake works	1	2	
	9	7	4

MECHANICAL ENGINEERING DRAWING AND DESIGN
UNIT 2 – PAPER 02
SOLUTIONS AND MARK SCHEME

Question 6.**Criteria**

- (a) (i) Draw a freehand sketch
(ii) Labelling
- (b) Reasons for its application
- (c) Identifying flaws

K	A	DS
3	3	3
3	6	
2		
8	9	3

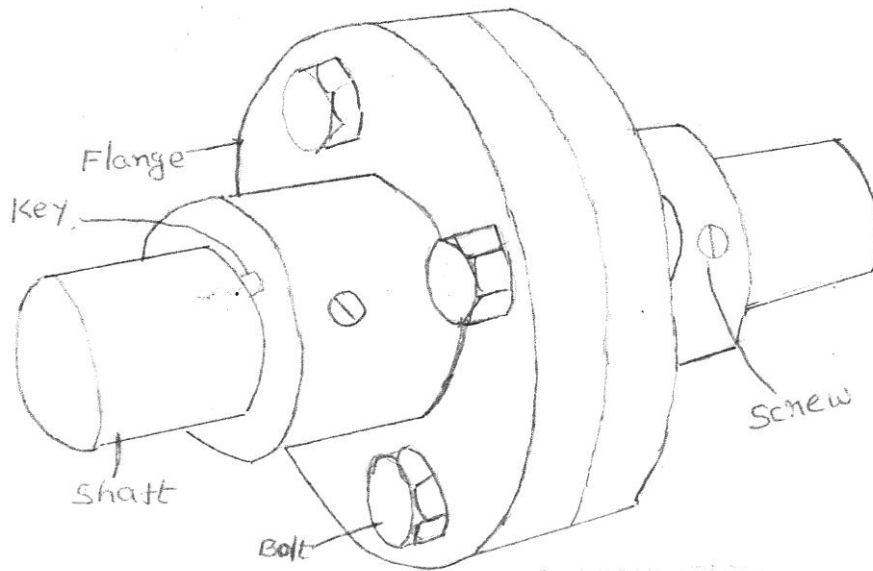

Flange coupling-pictorial representation

MECHANICAL ENGINEERING DRAWING AND DESIGN
UNIT 2 – PAPER 02
SOLUTIONS AND MARK SCHEME

(b) Reasons why the coupling can be used to connect a motor and generator:

- Provide a connection for shafts of the two units
 - Provide for misalignment of the shafts or introduce mechanical flexibility
 - Reduce the transmission of shock loads from one shaft to another
 - Alter the vibration characteristics of the motor and generator shafts
- Introduce protection against overloads. **(Any THREE - 2 marks each)**

(c) Flaws or defects in the flanged coupling can be identified by:

- Performing visual inspection
 - Checking for signs of wear or fatigue
 - Cleaning the coupling regularly
- (One mark each - any TWO)**

02269020/SPEC/2015

C A R I B B E A N E X A M I N A T I O N S C O U N C I L

CARIBBEAN ADVANCED PROFICIENCY EXAMINATION

BUILDING DRAWING AND DESIGN

SPECIMEN PAPER

UNIT 2 - PAPER 02

SOLUTIONS AND MARK SCHEME

BUILDING DRAWING AND DESIGN
UNIT 2 – PAPER 02
SOLUTIONS AND MARK SCHEME
Module 1

Question 1

	CRITERIA	K	A	DS
(a)	Drew the beam and loads to a convenient scale			1
	Drew the polar polygon	2	3	2
	Found the reactions	2	2	3
(b)	Compute the reactions analytically	1	4	
	TOTAL	5	9	6

BUILDING DRAWING AND DESIGN
UNIT 2 – PAPER 02
SOLUTIONS AND MARK SCHEME

Question 1 Cont'd

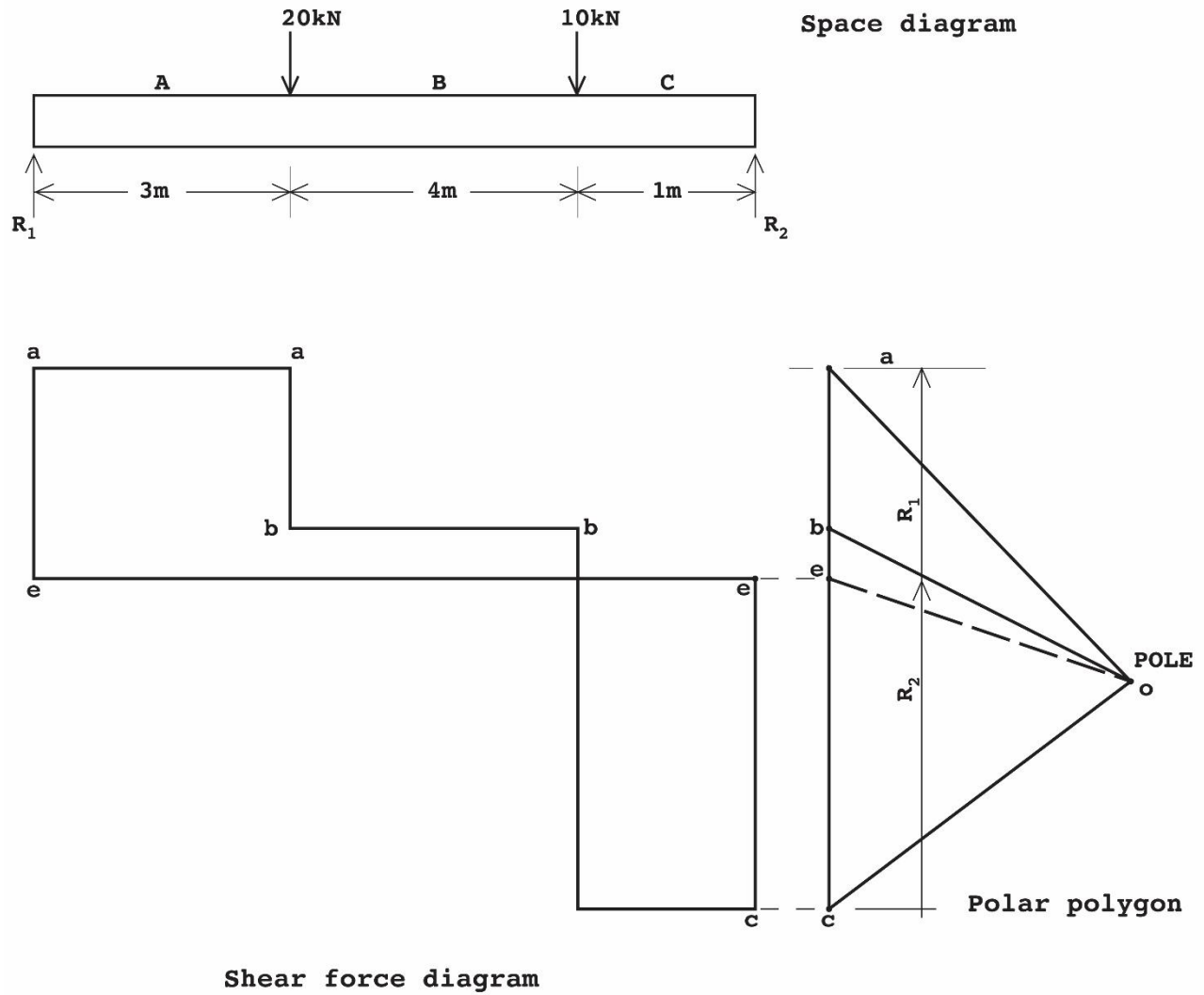

**BUILDING DRAWING AND DESIGN
UNIT 2 – PAPER 02
SOLUTIONS AND MARK SCHEME**

Question 2

	CRITERIA	K	A	DS
(a)	Sketch of column and footing	2	2	3
	Placement of reinforcement	1	1	3
	Labelling of components	3		
(b)	• L- corner stiffener detail	1		2
	• T- corner stiffener detail	1		1
	TOTAL	8	3	9

BUILDING DRAWING AND DESIGN
UNIT 2 – PAPER 02
SOLUTIONS AND MARK SCHEME

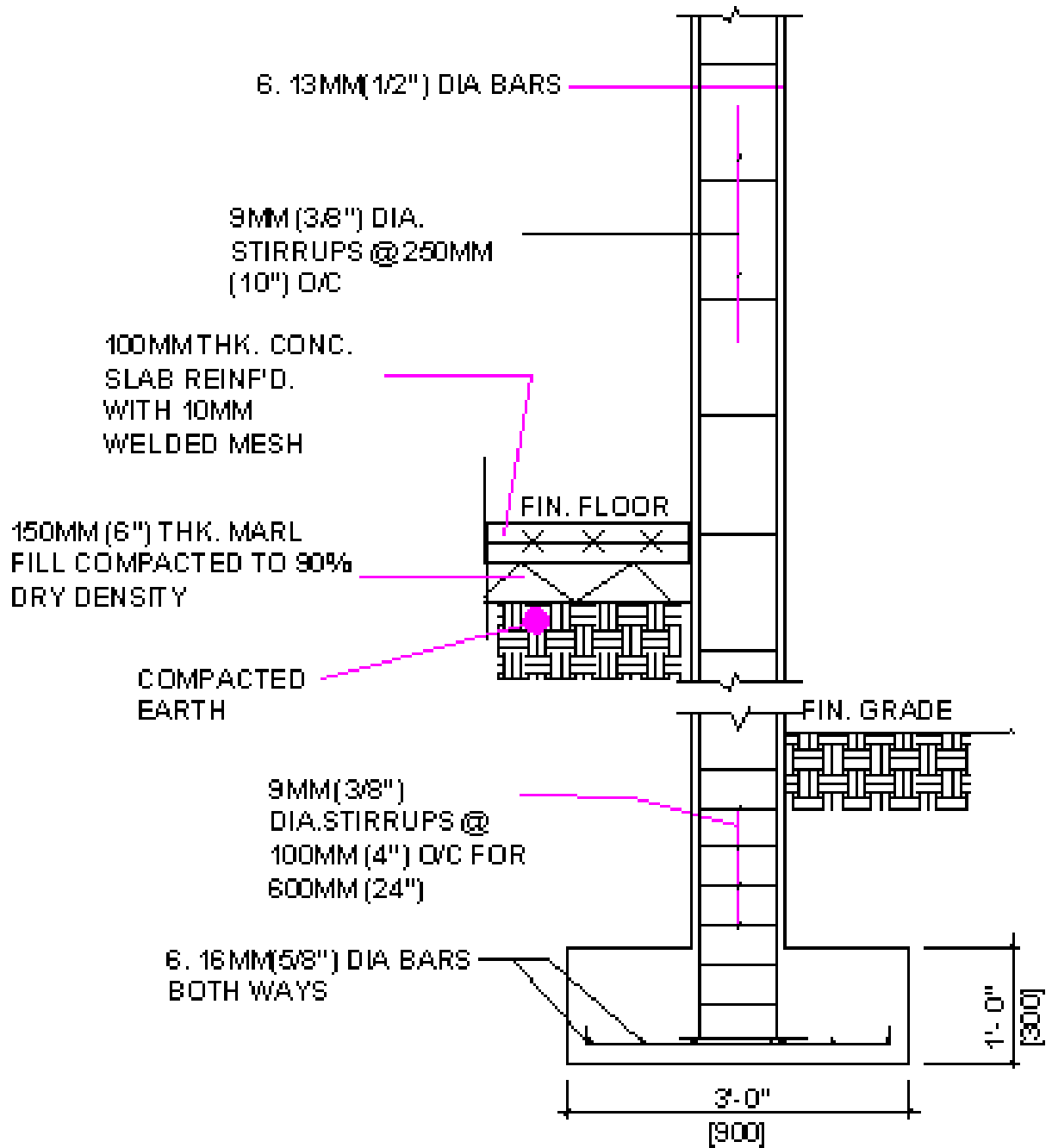

SECTION "THRU" COLUMN

BUILDING DRAWING AND DESIGN
UNIT 2 – PAPER 02
SOLUTIONS AND MARK SCHEME

Question 2 cont'd

(b) (i)

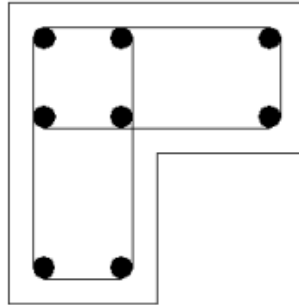

L STIFFENER

(b) (ii)

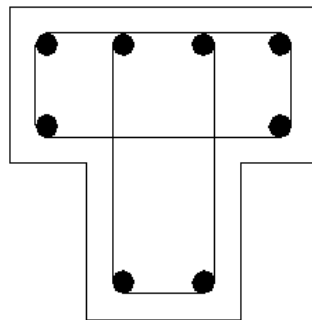

T STIFFENER

BUILDING DRAWING AND DESIGN
UNIT 2 – PAPER 02
SOLUTIONS AND MARK SCHEME
Module 2

Question 3

- (a) In preparing the concrete mix the inclusion of the correct quantity of each ingredient is critical as this ensures that the mix is economical, strong and workable. If too little of any ingredient is added it compromises the strength and workability of the mix while if too much ingredient is added it will invariably affect the cost of preparing the mix.
- (b) The amount of water used in relation to cement when preparing concrete mixes.
- (c) It affects the strength and workability of the concrete. High w/c ratio means less strength. Low w/c ratio means less workability.
- (d) The chemical reaction between cement and water in which new compounds with strength producing properties are formed over a 28 day period.

Two methods of connecting threads and risers on a timber staircase

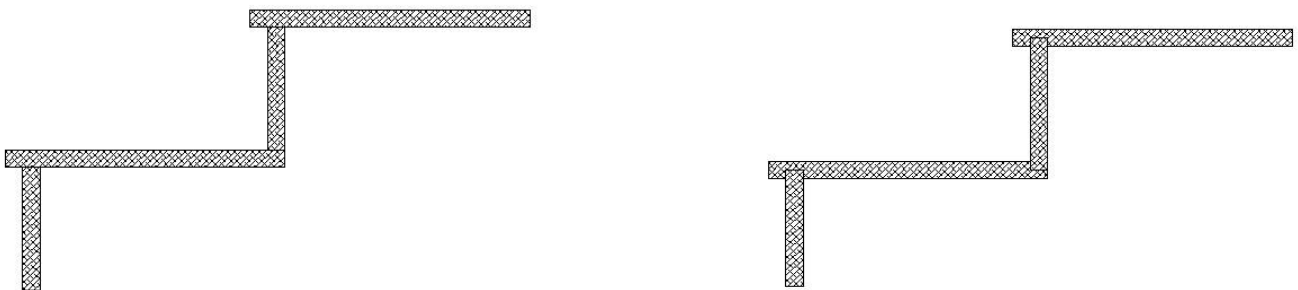

BUILDING DRAWING AND DESIGN
UNIT 2 – PAPER 02
SOLUTIONS AND MARK SCHEME

Question 3 cont'd

	CRITERIA	K	A	DS
(a)	Importance of batching concrete	2	2	
(b)	Define water/cement ratio	1		
(c)	Explain how water/cement ration affects concrete	1	2	
(d)	Explain hydration as it affects concrete	1	1	
(e)	Sketch two methods of connecting treads and risers		5	5
	TOTAL	5	10	5

BUILDING DRAWING AND DESIGN
UNIT 2 – PAPER 02
SOLUTIONS AND MARK SCHEME

Question 4

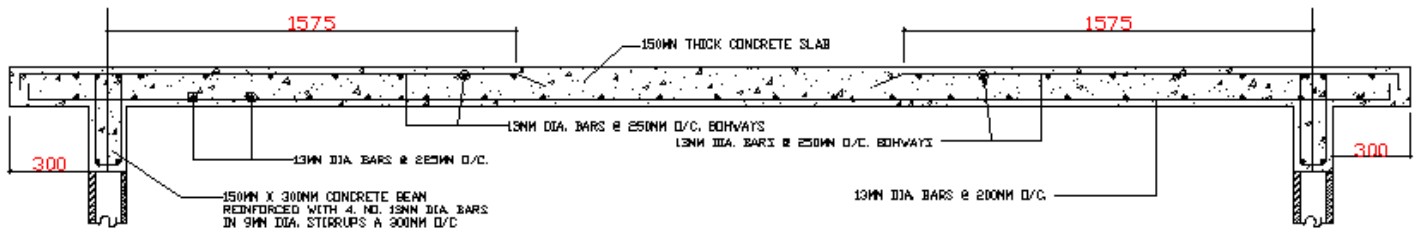

SECTION THROUGH CONCRETE SLAB
 SCALE 1:20

	CRITERIA	MARKS		
		K	A	DS
	Sketch section of floor slab	1	2	4
	Reinforcement detail	1	2	3
	Cantelever		2	1
	Details of section shown		2	
	Labelling	2		
	TOTAL	4	8	8

BUILDING DRAWING AND DESIGN
UNIT 2 – PAPER 02
SOLUTIONS AND MARK SCHEME
Module 3

Question 5

(a)

Project Activity Network

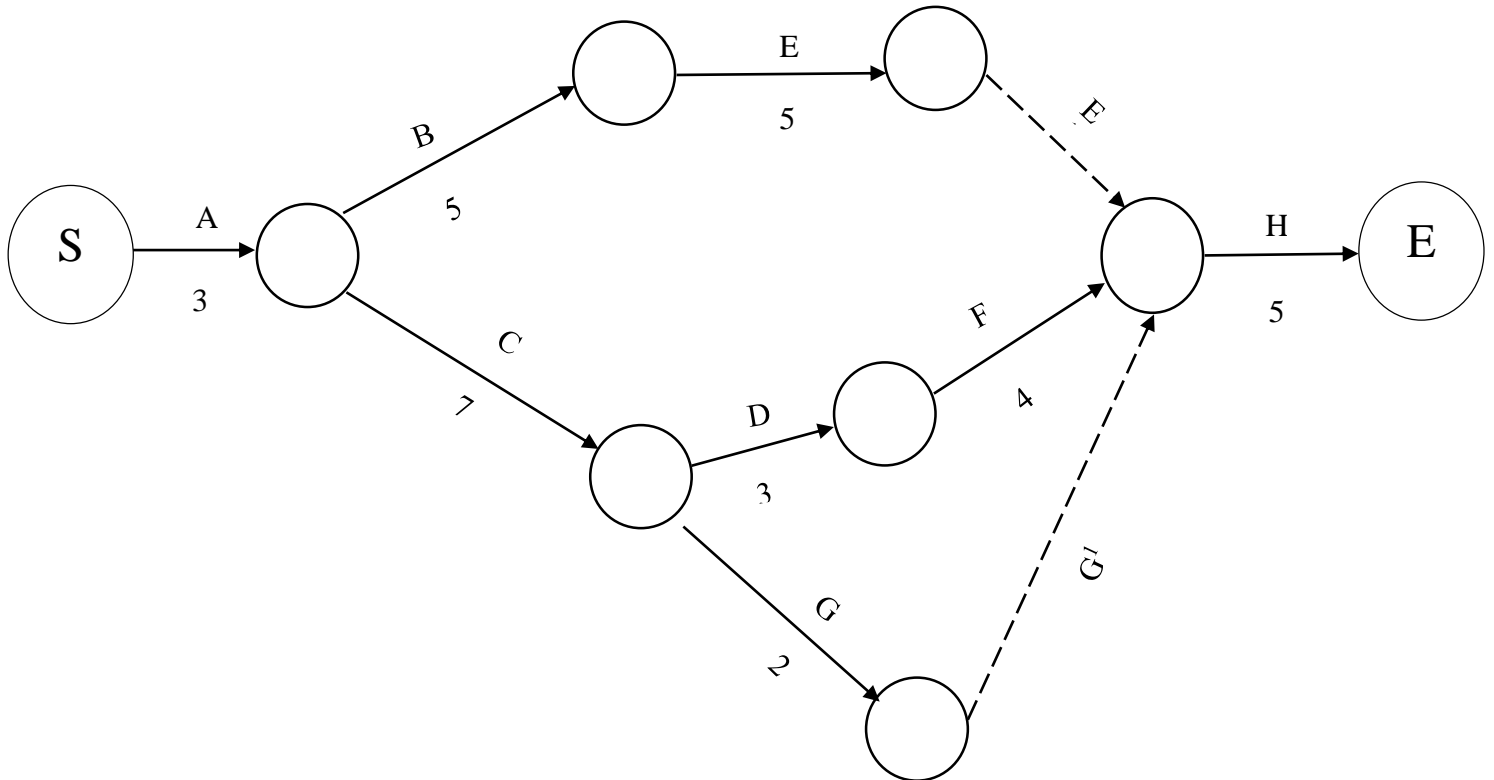

(b) Duration of project

$$A \ B \ E \ E' \ H = 3+5+5+0+5 = 18$$

$$A \ C \ D \ F \ H = 3+7+3+4+5 = 22$$

$$A \ C \ G \ G' \ H = 3+7+2+0+5 = 17$$

A C D F H is the critical path (22 days)

Duration of the project is 22 days

**BUILDING DRAWING AND DESIGN
UNIT 2 – PAPER 02
SOLUTIONS AND MARK SCHEME**

Question 5 cont'd

(c)

Activity	Duration	ES	EF	LS	LF	Slack
A	3	0	3	0	3	-
B	5	3	8	5	10	2
C	7	3	10	3	10	-
D	3	10	13	10	13	-
E	5	8	13	13	17	4
F	4	13	17	13	17	-
G	2	10	12	15	17	5

	CRITERIA	K	A	DS
(a)	Construct project activity network using AOA methodology	2	4	2
(b)	Determine duration of the project	2	2	
(c)	Calculate early start and finish, latest start and finish and slack time	2	6	
	TOTAL	6	12	2

**BUILDING DRAWING AND DESIGN
UNIT 2 – PAPER 02
SOLUTIONS AND MARK SCHEME**

Module 3

Question 6.

(a) **Stages of the design process.**

Recognition of need – the specific needs for such a building are identified, e.g. the two storey structure with two apartments. The designer would have to identify additional needs such as whether an apartment would be on each level or whether each apartment would utilize both levels.

Definition of problem – a clear definition of the problem is required to be certain that all needs are taken care of during the design phase. Issues such as accessibility, use and number of occupants per apartment would have to be clarified.

Synthesis – Several solutions are identified through brainstorming. Where necessary these are sketched or drawn and checked for conformity to solving the problem. At this stage, investigations are carried out to identify possible customers' likes and dislikes. The goal is to identify as many solutions as possible.

Analysis and optimization – various analytical techniques are employed to identify the best solution. For example, consistency testing, economic analysis, engineering analysis are employed to optimize the best results.

Evaluation – the solutions are evaluated to determine the best useable solution. This can be achieved using scale models, diagrams etc. Other factors evaluated can include but are not limited to reliability of structural members, strength, environmental impact and safety.

Presentation – at this stage, solutions are presented to clients to gauge reactions and to determine meeting of needs. All data and designs generated are communicated to the clients for their input and for selection of the final solution.

- (b) In the design of the apartment building, the principle of aesthetics is key to ensuring the building has a particular look that appeals to the senses of those using or observing the building. Attributes such as colour, texture, shape, pattern, balance and repetition are critical to achieving the aesthetic appeal of the building. The product designer needs a knowledge of these attributes to successfully design the building.

**BUILDING DRAWING AND DESIGN
UNIT 2 – PAPER 02
SOLUTIONS AND MARK SCHEME**

Question 5. (cont'd)

MARK SCHEME

CRITERIA			K	A	DS
(a)	Identification of each stage of the design process	(1 mark each)	6		
	Explanation of each design stage	(2 marks each)	6	6	
(b)	Explanation of the design principle of aesthetics			2	
			12	8	